

A7V变量柱塞泵

配件示意图



A7VO系列柱塞泵配件

- | | |
|-------------------|----------------------|
| 1、齿轮泵 gear pump | 6、凌圈 ring of piston |
| 2、中心轴 centre pin | 7、缸体 cylinder block |
| 3、传动轴 drive shaft | 8、配油盘 valve plate |
| 4、螺钉 socket bolt | 9、回程盘 retainer plate |
| 5、碟簧 disc spring | 10、柱塞 piston shoe |

A7V变量柱塞泵

结构示意图

OH-A7V 变量柱塞泵 Variable Displacement Pump OH-A7V

说明

- ※斜轴式轴向柱塞泵，用于开式回路静液压传动中。
- ※流量与驱动转速及排量成正比，在恒定驱动转速下，可实现无级变量。
- ※控制装置品种齐全，用于每种控制和调节功能。
- ※用矿物油和抗燃液体工作。



Description

- ※Variable displacement pump, axial piston, bent axis design, for hydrostatic transmissions in open circuits.
- ※The flow is proportional to the drive speed and the displacement and is steplessly variable at constant drive speed.
- ※Comprehensive programme of control devices for every control and regulation function.
- ※Operation of both mineral, and fire-resistant fluids.

结构特点

- ※高性能的旋转组件及球面配油盘，可实现自动对中，低周速，高效率。
- ※驱动轴能承受径向载荷。
- ※长寿命。
- ※低噪声级。

Special Features

- ※High performance rotary group with spherical control area offering the following advantages: self-centering, low peripheral speed, high efficiency.
- ※Drive shaft will support radial loads.
- ※Long service life.
- ※Low noise level.

剖视图 Section

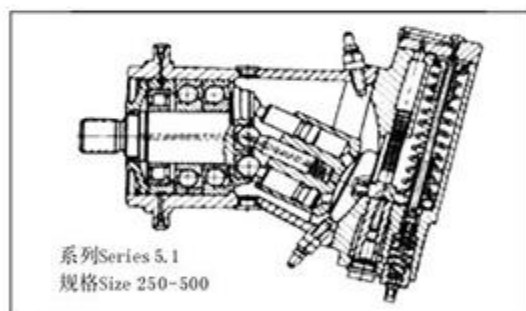
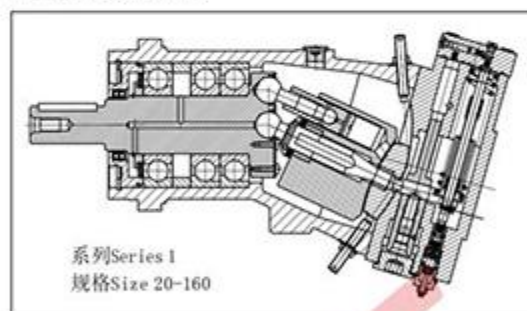

注意事项

注意：泄漏油（壳体泄油）温度受压力和转速的影响，总是高于回路温度，然而要求回路中任何点温度不得超过90℃。

泵的进口压力须 $\geq 0.08\text{MPa}$ （绝对压力），及泄油压力（壳体内允许的最高压力）须 $\leq 0.2\text{MPa}$ （绝对压力），壳体内压力值必须等于或高于作用在轴密封上的外部压力值。

《样本》所述技术资料，仅供参考。若有特殊要求请与我公司技术部门咨询，若有更改，恕不通知。

NOTES

Important: The leakage oil (case drain oil) temperature is influenced by pressure and pump speed and is always higher than the circuit temperature. However, at no point in the circuit may the temperature exceed 90℃.

The minimum pressure at the suction port of the pump $\geq 0.08\text{MPa}$ (absolute pressure), and the drain pressure (max. permissible casing pressure) is 0.2MPa (absolute pressure). The pressure in the housing must be the same or greater than the external pressure to the shaft seal.

The technical information in the catalog is for your reference. Please consult our technical Dept., if you have any special requirements.

型号标识 Type Code

OH-A7V	55	LV	1	L	Z	F	0	0
1	2	3	4	5	6	7	8	9

1-结构型式 Machinery Type

轴向柱塞, 斜轴式, 可变量 Axial piston, bent axis, variable	OH-A7V
--	--------

2-规格 Size

排量 Displacement mL/r	20	28	40	55	58	80	78	107	117	160	250	500
----------------------	----	----	----	----	----	----	----	-----	-----	-----	-----	-----

3-变量机构 Control Device

恒功率变量 Constant power control	LV
恒功率负荷传感变量 Constant power control with load sensing	LVS
恒压变量 Constant pressure control	DR
恒压负荷传感变量 Constant pressure control with load sensing	DRS
手动变量 Manual control	MA

4-系列 Series

规格 Size 20-160	1
规格 Size 250-500	5.1

5-旋转方向 (从轴端看) Rotating Direction (View on Shaft End)

顺时针 Clockwise	R
逆时针 Counterclockwise	L

6-轴伸 Shaft End

花键 Splined shaft DIN 5480	Z
花键 Splined shaft GB 3478.1-83	S
平键 Keyed shaft GB1096-79	P

7-油口型式 Ports Type

压力油口: SAE法兰, 在侧面。 Pressure port: SAE flange, on side. 吸油口: SAE法兰, 在侧面。 Suction port: SAE flange, on side.	F
压力油口: 螺纹连接, 在侧面。 Pressure port: threaded, on side. 吸油口: SAE法兰, 在侧面。 Suction port: SAE flange, on side.	G

8-行程限位 Stroke Limiter

没有 none	O
机械行程限位 (用于LV和DR) Stroke limiter, mechanically adjustable (for LV and DR)	M
液压行程限位 (用于LV) Stroke limiter, hydraulic (for LV)	H

9-辅助元件 Auxiliary Equipment

没有 None	O
带压力切断 With pressure cut-off	D

订货示例 Ordering Example: OH-A7V. 55. LV. 1. L. Z. F. 0. 0

轴向柱塞变量泵 OH-A7V, 规格 55, 恒功率控制, 系列 1, 逆时针旋转, 轴伸 Z 花键, SAE 法兰连接, 没有行程限位器和辅助元件。

Axial piston variable displacement pump OH-A7V, size 55. With constant power control, series 1.

Anti-clockwise rotation, splined shaft, SAE flange connections, without stroke limiter and auxiliary equipment.

技术参数 Technical Data

1、进口工作压力范围 (绝对压力)

Inlet Operation Pressure Range (Absolute pressure)

最低压力 p_{min}	0.08MPa
最高压力 p_{max}	0.2MPa

2、出口工作压力范围

Outlet Operating Pressure Range

额定压力 p_n	35MPa
峰值压力 p_{max}	40MPa

3、参数表 Technical Data

(理论值, 未考虑机械效率和容积效率 Theoretical values, without considering mechanical efficiency and volumetric efficiency)

规格 Size			20	28	40	55	58	80	78	107	117	160	250	355	500
排量 Displacement	V_{max} mL/r		20.5	28.1	40.1	54.8	58.8	80	78	107	117	160	250	355	500
	V_{min} mL/r		0	8.1	0	15.8	0	23.1	0	30.8	0	46.2	0	0	0
控制机构 Control devices ● = 可以配置 Available	LV		●	●	●	●	●	●	●	●	●	●	●	●	●
	LVS										●				
	DR		●		●		●		●		●		●	●	●
	DRS										●				
	MA		●	●	●	●	●	●	●	●	●	●	●		
最高转速 ³ Max. Speed	在 $0.09MPa^1$	$n_{max.09}$ r/min	3800	2800	3200	2360	2850	2120	2540	1900	2240	1650	1400	1250	1120
	在 $0.1MPa^1$	$n_{max.1}$ r/min	4100	3000	3400	2500	3000	2240	2700	2000	2360	1750	1500	1320	1200
	在 $0.15MPa^1$	$n_{max.15}$ r/min	4750	3600	3750	3000	3350	2750	3000	2450	2650	2100	1850	1650	1500
最大流量 ² Max. Flow	在 $n_{max.09}$	$Q_{max.09}$ L/min	76	76	124	125	161	164	192	197	254	256	340	430	543
	在 $n_{max.1}$	$Q_{max.1}$ L/min	82	82	132	133	170	174	204	208	267	271	364	455	582
	在 $n_{max.15}$	$Q_{max.15}$ L/min	94	98	146	160	190	213	227	254	300	326	449	568	782
最大功率 Max. Power ($\Delta p=35MPa$)	在 $Q_{max.09}$	$P_{max.09}$ KW	45	46	75	75	97	99	116	119	153	154	204	259	326
	在 $Q_{max.1}$	$P_{max.1}$ KW	49	49	80	80	102	105	123	125	161	163	218	273	350
	在 $Q_{max.15}$	$P_{max.15}$ KW	57	59	88	96	114	128	136	153	181	196	270	342	437
流量 Flow	在 $n_c=1450r/min$	Q L/min	28.8	39.5	56.4	77.1	82.3	112.5	109.7	150.5	164.6	225	-	-	-
功率 Power ($\Delta p=35MPa$)	在 $n_c=1450r/min$	P KW	17	24	34	46	50	68	66	91	99	135	-	-	-
扭矩 Torque ($\Delta p=10MPa$)	在 V_{max}	M Nm	32.6	44.6	63.7	87	93.2	127.5	124	169.7	186	254	397.5	564.5	795
	在 V_{min}	M Nm	-	12.9	-	25.1	-	36.8	-	49	-	73.5	-	-	-
扭矩 Torque ($\Delta p=35MPa$)	在 V_{max}	M Nm	114	156	223	305	326	446	431	594	651	889	1391	1975	2782
	在 V_{min}	M Nm	-	45	-	88	-	129	-	171	-	257	-	-	-
惯性矩 Moment		J kgm ²	0.0017	0.0017	0.0052	0.0052	0.0109	0.0109	0.0167	0.0167	0.0322	0.0322	0.088	0.1600	0.2700
重量 Weight		kg	19	19	28	28	44	44	53	53	76	76	105	165	245

1、所示值为吸油口S的绝对压力,且在 V_{max} 用矿物油工作。

2、以容积效率97%算出。

3、即使在更高的负载下,最高转速不得超过0.15MPa时的数值。在28-20、55-40、80-58、107-78、160-117各组规格中,对于 $V_{min}>0$ 的那些规格,通过减少排量($V_e < V_{max}$)和维持最大流量,最高转速可提高到本组的 $V_{min}=0$ 规格的值。

1. The values shown are valid for V_{max} . With an absolute pressure at suction inlet S and when operated on mineral oil.

2. Calculated with a volumetric efficiency of 97%.

3. The maximum speeds at 0.15MPa shown must not be exceeded, even with higher loading. On those sizes with $V_{min}>0$, however the maximum speeds can be increased to the values for those sizes with $V_{min}=0$ by reducing the displacement ($V_e < V_{max}$) and maintaining max. flow. The relevant sizes are 28-20, 50-40, 80-85, 107-78, 160-117.

安装位置 Mounting Position

任选。泵壳内必须始终充满油液。当装于油箱内时，油口R的螺塞必须取下，此油口必须在顶部，并拧上一个90°的弯头（以减少噪音）。

Optional. The pump housing must always be filled with oil. When mounting within a tank the plug must be removed from port R and this port must be at the top. 90° pipe bend to be screwed in (noise reduction).

驱动轴朝上垂直安装 Vertical mounting with drive shaft pointing upwards 对此必须定货带有油口U₁和U₂的型号（用文字说明带U₁和U₂）。最低液面不低于“A”线，如图1所示。

该泵装于油箱内时油口U₁和U₂的螺塞必须取下，当装于油箱外时，泵在启动前必须在油口U₁或U₂排气。

For this case a model with ports U₁ and U₂ must be ordered (indicate in clear text: "with ports U₁ and U₂"). The minimum oil level must not fall below the "A" line, as shown in Fig1.

When mounting within a tank the plug must be removed from ports U₁ and U₂. When mounting outside a tank, the pump must be bled at port U₁ or U₂ prior to commissioning.

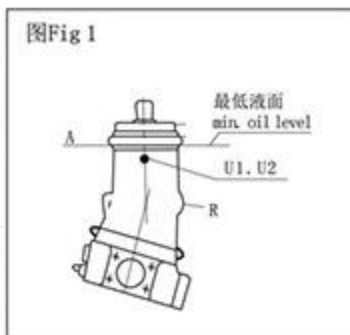

泵装于油箱顶部 Mounting on Top of Tank

OH-A7V变量泵装于油箱顶部应看作特殊安装，只能在特定的条件下实现，订货时请注明：用于油箱顶部安装。这种安装要求吸油口位于上方，吸油管尽可能短，管端至少低于最低液面200mm，见图2。吸油管的内径应保证油的流速在0.8至1m/s之间。

这种安装只能在泵处于最大摆角（V_{max}）时启动，对于调节从V_{max}开始的泵，Q_{min}限位螺钉必须调到最小流量≥V_{max}5%处，以免在零位工作时吸油管放空。

Mounting of the OH-A7V variable pump above tank must be considered as a special pump installation and should only be realized under specific conditions.

When ordering pumps for mounting on top of tank, state in clear text: "To Be Used for Above Tank Mounting"

This installation requires that the suction port be at the top and the suction pipe be kept as short as possible and the end of the pipe be at least 200mm below minimum oil level, see Fig2. The cross-cut of the suction pump should be dimensioned to ensure that the flow velocity of the pressure fluid lies between 0.8 and 1m/s.

Start-up of the pump with all controls is only possible when the pump is at its full swivel angle (V_{max}). For pumps with minimum flow of ≥5% of V_{max}. In order to avoid emptying of the suction line during zero position operation.

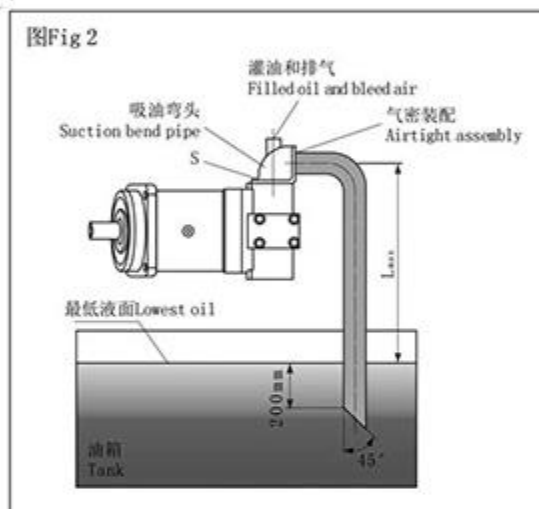

安装于油箱顶部时的转速，吸油管长度与内径

规格 Size	最高转速 ¹⁾ Max. Speed n _{max} r/min	吸油管最大长度 Max. Length of suction pipe L _{max} (mm)	在流速V=0.9m/s和V _{max} 下算出的吸油管内径(mm) Calculated suction pipe I.D. (mm) at flow velocity V=0.9m/s and V _{max}	
			speed转速 n _{max} (r/min)	speed转速 n=1450 (r/min)
20	3610	600	41.8	26.5
28	2660	600	42	31
40	3040	750	53.6	37
55	2240	750	53.8	43.3
58	2700	750	61.3	45
80	2015	750	61.6	52.3
78	2410	750	66.6	51.6
107	1800	750	67.5	60.5
117	2125	850	76.6	63.3
160	1565	850	77	74

1) 此数值仅适用于吸油口绝对压力为0.09MPa，排量为V_{max}及用矿物油工作时。

The values shown are valid for V_{max} with 0.09MPa absolute pressure at suction inlet S and when operated on mineral oil.

LV恒功率变量 Constant Power Control

恒功率变量是驱动转速不变时，按照负载压力控制流量，以保持油泵输出的液压功率恒定。

The constant power control controls flow in relation to pressure, thereby maintaining hydraulic power constant. (Provided that the drive speed is constant.)

$$P = \frac{p \cdot Q}{60} = \text{常数 Constant}$$

P—功率power [KW]

p—压力pressure [MPa]

Q—流量flow [L/min]

变量起点 Commencement of control: min. 5MPa

通过油口G的并联可实现总功率变量

Summation power control possible by throttles via port G.

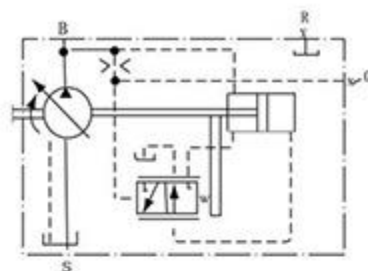

恒功率变量LV
Constant power control

行程限位器 Stroke Limiter

通过机械行程限位器或液压行程限位器可无级的改变或限制最大排量，调节范围从 V_{min} 到 V_{max} 。

By means of a mechanical or hydraulic stroke limiter, the max. displacement can be infinitely varied or limited. Adjustment range from V_{min} to V_{max} .

机械行程限位器 Mechanical stroke limiter

规格 Size	20	40	58	78	117	250
螺杆转数 Spindle Revolutions	23	21	28	31	26	21.25
所需扭矩 Required Torque (approx.) Ncm	80	140	500	630	-	-

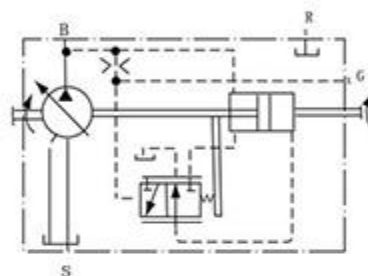

带机械行程限位的恒功率变量LV.....M
Constant power control with mechanical stroke limiter

液压行程限位器 Hydraulic stroke limiter

液压行程限位器需要不小于工作压力10%的先导压力（X1油口）。油口X1的最高允许压力=30MPa（对所有规格），如果需要限制工作压力<5MPa时的流量，则需在油口X2施加不低于5MPa的供油压力（油口X1压力为 $5 \times 10\% = 0.5\text{MPa}$ ）。

A Pilot pressure (port X1) of at least 10% of the operating pressure is required for the hydraulic stroke limiter. Max. permissible pressure at port X1=20MPa (for all sizes)

if it is required to limit the flow at operating pressure < 5MPa then a pilot pressure of min 0.5MPa must be applied at port X2 (at port X1 then, min 10% = 0.5MPa)

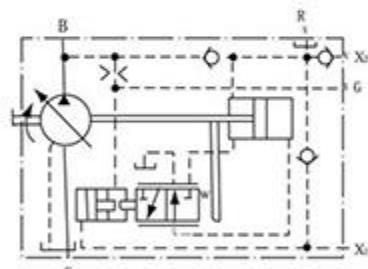

带液压行程限位的恒功率变量LV.....H
Constant power control with hydraulic stroke limiter

辅助元件

压力切断

适用于 $V_{min}=0$ 的所有规格。

压力切断是叠加在恒功率控制的恒压控制，它借助于顺序阀，当达到设定的最高压力时（调节范围到31.5MPa），该阀打开，流量自动减少至 $Q=0$ 。顺序阀与泵分开安装，可装于任何适当位置（遥控）的底板上，其连接管长（单管）不得大于5m，顺序阀与底板需要单独订货。

当采用带压力切断的恒功率变量时，泵变量时间将比恒压变量泵DR的长3倍。

注意：顺序阀油口T和先导回油口T1必须直接通回油箱。

在零位连续工作见DR恒压变量。

Auxiliary Equipment

Pressure cut-off

For all sizes with $V_{min}=0$

The pressure cut-off is a constant pressure control superposed on the constant power control and is carried out by means of a sequence valve. When the set. maximum pressure is reached (adjustment range up to 31.5MPa), the valve opens and the flow is automatically reduced (to $Q=0$).

The sequence valve is mounted separately from the pump in any suitable location on a subplate (remote control).

When using the constant power control with pressure cut-off, the pump control times, will be approximately 3 times longer than those obtained with the constant pressure control DR.

Important: Port T from the sequence valve and pilot oil return line T1 must be piped direct to tank (cooler). Continuous operation in

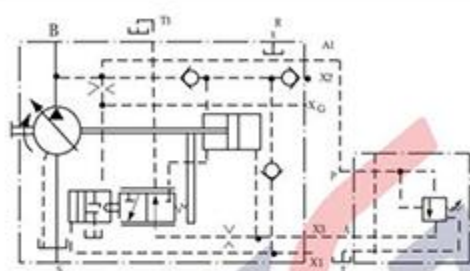

带压力切断（遥控）和液压行程限位的恒功率变量LV……HD
Constant power control with pressure cutoff
(remote controlled) and hydraulic stroke limiter

油口 Ports

- B 压力油口 Pressure port
- S 吸油口 Suction port
- G 总功率控制油口 Port for summation power control line
- X1 先导压力口 Pilot pressure
- X2 遥控口 Remote control pressure
- A1、X3 遥控阀油口 Ports for remote control valve
- T1 先导回油口 Pilot oil return
- R 排气口 Air bleed

变量功率设定范围 Variable power setting range

规格 Size		20	28	40	55	58	80	78	107	117	160	250
转速 Speed	n: r/min	1450										
流量 Flow	Q: L/min	28	39	57	77	81	110.5	110	150	165	225	237
不带压力切断的设定范围 Without pressure cut-off	P _{max} K W	3	4	5.5	7.5	7.5	11	11	15	15	22	22
	P _{max} K W	11	15	18.5	30	30	37	37	45	55	75	90
带压力切断的设定范围 With pressure cut-off	P _{max} K W	3	-	5.5	-	7.5	-	11	-	15	-	22
	P _{max} K W	10	-	18.5	-	27	-	37	-	55	-	90

DR恒压变量 Constant Pressure Control

恒压变量在其变量范围内保持系统压力恒定不受泵流量变化的影响，变量泵仅供应工作必须的油液体积。如果压力超过设定值，则泵自动摆回小角度。

所需压力可直接在泵上设定（阀内装，标准型），设定范围5—35MPa。对于遥控型单独在顺序阀上设定，遥控型设定范围5—31.5MPa。

恒压变量适用于V_{min}=0的所有规格。

The constant pressure control maintains the pressure in a hydraulic system constant within its control range in spite of changing pump flow requirements. The variable pump supplies only the volume of fluid required by the services. Should operating pressure exceed the set pressure, the pump is automatically swiveled back to a smaller angle.

The required pressure is set either direct at the pump (valve built in standard model) or at the separate sequence valve for the model with remote control. Setting range from 5 to 35MPa. Setting range for remote control 5 to 31.5MPa.

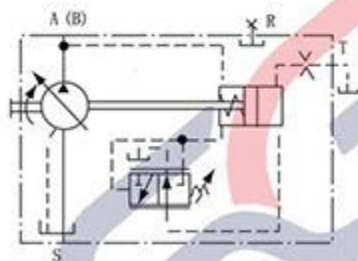

恒压变量DR（阀内装）
Constant pressure control DR (valve built-in)

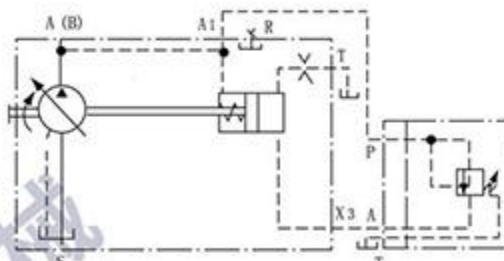

恒压变量DR（遥控）
Constant pressure control DR (remote controlled)

注：顺序阀和底板须单独订货。最大遥控管单根长度不超过5m。顺序阀油口T须单独接回油箱，装于系统中用于压力保护的安全阀，其压力设定必须比恒压变量的压力设定值高2MPa。

Note: Order sequence valve subplate separately. The max. single pipe length should not exceed 5m. Port T from the sequence valve must be piped separately to tank. A pressure relief valve installed in the system for protection of the max. pressure must be set 2MPa above the setting of the constant pressure control.

调节时间 Adjustment Times

规格Size	20	40	58	78	117
$V_{max}-V_{min}$ te(S) 卸压35-5MPa Pressure unloading	0.16	0.2	0.25	0.25	0.3
$V_{max}-V_{min}$ ta(S) 升压5-35MPa Pressure built-up	0.03	0.04	0.05	0.05	0.06

对于遥控, 表中数值增大3倍。
The values in the table are increased by 3 times for remote control.

行程限位 Stroke Limiter

借助于机械行程限位器可把最大排量无级地限制在 V_{min} 与 V_{max} 之间, 详见LV变量。
The max. displacement can be steplessly limited between V_{min} to V_{max} by means of a mechanical stroke limiter.
For details see control device LV.

在零位连续工作 Continuous Operation in Zero Position

不带壳体冲洗的零行程工作
Zero stroke operation without flushing of housing

短期 Short periods < 10min	最高允许压力 max. pressure P_{max} (MPa)	31.5
	最高允许温度 max. temperature t_{max} (C)	50
长期 Long periods	最高允许压力 max. pressure P_{max} (MPa)	20
	最高允许温度 max. temperature t_{max} (C)	50

并联工作 Parallel Operation

几台OH-A7V恒压变量泵并联工作时, 其恒压曲线较陡。
在订货时请注明“并联工作”。
并联工作时每台泵需要各自的顺序阀。

For parallel operation of several OH-A7V pumps with constant pressure control. A steeper curve is used for the constant pressure control.

Please indicate this requirement in text after the type code when order in ("parallel operation")

For parallel operation each individual pump requires its own sequence valve.

带壳体冲洗的零行程工作-
Zero stroke operation without flushing of housing

长期 Long periods	最高允许压力 max. pressure P_{max} (MPa)	31.5
	最高允许温度 max. tank temperature t_{max} (C)	50

冲洗流量 Flushing flow

规格Size	20	40	58	78	117	250
流量 flow Q_{sp} L/min	2	4	6	8	12	12.5

当OH-A7V泵装于油箱顶部在 P_{max} 为31.5MPa下长时间零行程工作时, 必须提供 \geq 上表对应规格的冲洗流量对壳体冲洗。

Note: When mounting the OH-A7V on top of tank and at zero stroke operation for longer periods of time at pressure up to P_{max} 31.5MPa a minimum flow \geq corresponding to flushing flow as indicated for each size in the above table must be set instead of case flushing.

冲洗液温度 \leq 油箱温度
Temperature of flushing fluid \leq tank temperature

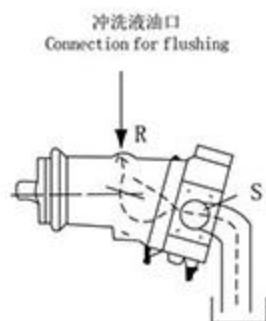

MA手动变量 Manual control

通过转动手轮借助于螺杆使变量活塞沿轴向运动, 并经拨销使配油盘沿其滑动面运动, 从而使泵在 V_{min} 至 V_{max} 范围内无级地改变其排量。

By turning the handwheel, a piston is moved in an axial direction by means of a threaded spindle. A carrier pin moves the control lens on its sliding plane, thus permitting stepless variation of the pump displacement in the range V_{min} to V_{max} . The pump position indicator is located in the handwheel.

油口 Ports

B 压力油口 Pressure port
S 吸油口 Suction port
R 排气口 Air bleed

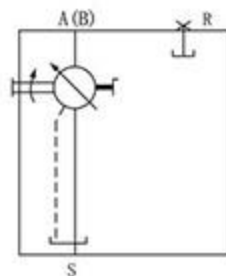

手动变量MA
Manual control

元件尺寸 Unit Dimensions
LV恒功率变量 Constant Power Control

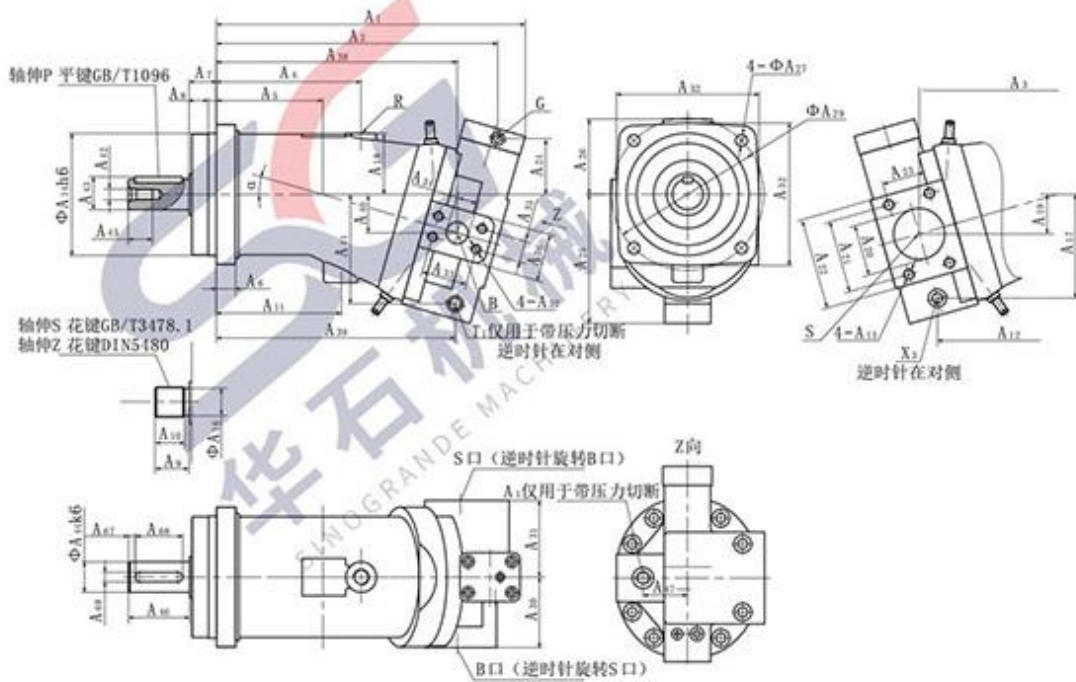

带行程限位的恒功率变量 Constant power control with stroke limiter

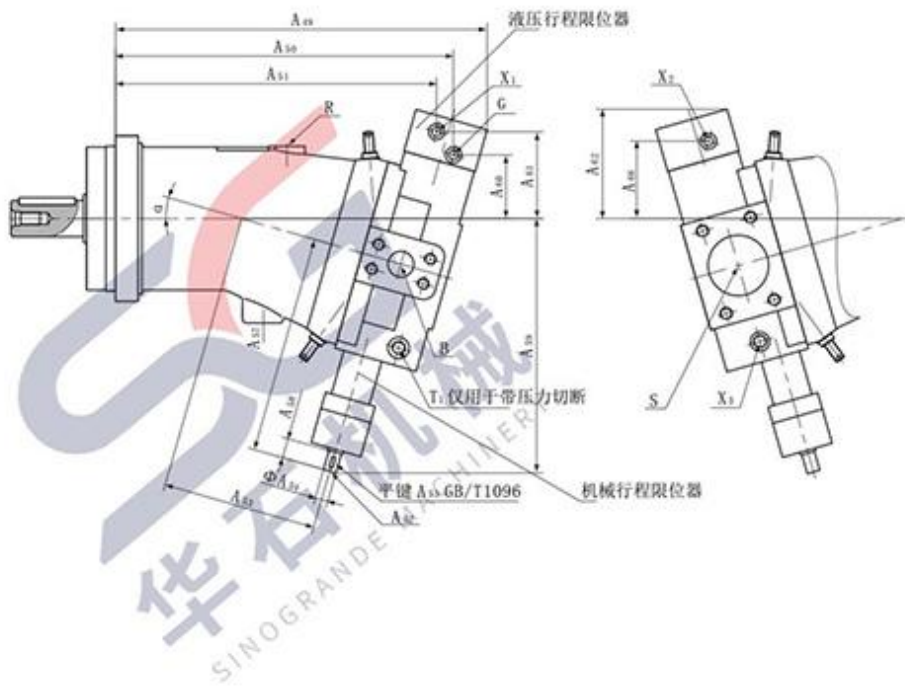

外形尺寸表Dimension Size

规格 Size	a	A ₁	A ₂	A ₃	A ₄	A ₅	A ₆	A ₇	A ₈	A ₉	A ₁₀	A ₁₁	A ₁₂	A ₁₃	A ₁₄	A ₁₅	A ₁₆	A ₁₇	A ₁₈	A ₁₉	A ₂₀	A ₂₁	A ₂₂	A ₂₃	A ₂₄
20	9°	251	224	199	107	75	16	25	8	43	28	80	160	M12深20	100	21.5	85	52	20	38	69.9	94	35.7	78	
28	16°	260	232	195	107	75	16	25	8	43	28	80	149	M12深20	100	21.5	95	50	34	38	69.9	94	35.7	59	
40	9°	317	287	255	123	108	20	32	10	35	28	123	244	M12深20	125	25	95	63	23	50	77.8	102	42.9	87	
55	16°	327	296	251	123	108	20	32	10	35	28	123	-	M12深20	125	25	-	63	41	50	77.8	102	42.9	64	
58	9°	374	337	304	152	137	23	32	10	40	33	152	295	M12深18	140	30	106	77	26.5	63	88.9	115	50.8	93	
80	16°	385	351	300	152	137	23	32	10	40	33	152	-	M12深18	140	30	-	77	48	63	88.9	115	50.8	68	
78	9°	381	347	310	145	130	25	40	10	45	37.5	145	298	M12深17	160	35	113	80	29	63	88.9	115	50.8	101	
107	16°	393	358	305	145	130	25	40	10	45	37.5	145	-	M12深17	160	35	-	80	50	63	88.9	115	50.8	73	
117	9°	443	402	361	214	156	28	40	12	50	43	174.5	350	M16深24	180	40	130	93	33	75	106.4	135	61.9	114	
160	16°	454	414	359	214	156	28	40	12	50	43	174.5	-	M16深24	180	40	-	88	58	75	106.4	135	61.9	83	

规格 Size	A ₂₅	A ₂₆	A ₂₇	A ₂₈	A ₂₉	A ₃₀	A ₃₁	A ₃₂	A ₃₃	A ₃₄	A ₃₅	A ₃₆	A ₃₇	A ₃₈	A ₃₉	A ₄₀	A ₄₁	A ₄₂	A ₄₃	A ₄₄	A ₄₅	A ₄₆	A ₄₇	A ₄₈	A ₄₉
20	132	95	11	125	58	58	118	50.8	19	23.8	46	M10深17	193	-	19	-	M8	27.9	25	19	50	38	257	226	
28	145	80	11	125	58	58	118	50.8	19	23.8	46	M10深17	189	-	33	-	M8	27.9	25	19	50	38	269	234	
40	166	109	13.5	160	71	81	150	50.8	19	23.8	53	M10深17	253	261	23	98	M12	33	30	28	60	40	323	290	
55	182	91	13.5	160	71	81	150	50.8	19	23.8	53	M10深17	249	-	40	-	M12	33	30	28	60	40	337	299	
58	168	113	13.5	180	86	92	165	57.2	25	27.8	64	M12深18	301	313	26	109	M12	38	35	28	70	62	378	344	
80	194	-	13.5	180	86	92	165	57.2	25	27.8	64	M12深18	300	-	48	-	M12	38	35	28	70	62	391	354	
78	180	120	17.5	200	89	93	190	57.2	25	27.8	64	M12深18	306	318	28	119	M12	43	40	28	80	55	385	352	
107	200	98	17.5	200	89	93	190	57.2	25	27.8	64	M12深18	301	-	49	-	M12	43	40	28	80	55	400	363	
117	195	137	17.5	224	104	113	210	66.7	32	31.8	70	M14深19	359	369	32	136	M16	48.5	45	36	90	65	445	408	
160	212	112	17.5	224	104	113	210	66.7	32	31.8	70	M14深19	354	-	57	-	M16	48.5	45	36	90	65	461	420	

规格 Size	A ₅₁	A ₅₂	A ₅₃	A ₅₄	键A55 GB/T3107.1	A ₅₇	A ₅₈	A ₅₉	A ₆₀	A ₆₁	A ₆₂	A ₆₃	A ₆₄	A ₆₅	A ₆₆	A ₆₇	A ₆₈	A ₆₉	S轴花键 GB/T3478.1			Z轴花键 DIN5480		
20	230	M3深9	108	8	键2×10	161	14	176	77	104	129	228	92	5	40	8	EXT18z×1.25m×30R×5f	W25×1.25×30×18×9g						
28	242	M3深9	108	8	键2×10	161	14	186	58	84	114	238	73	5	40	8	EXT18z×1.25m×30R×5f	W25×1.25×30×18×9g						
40	279	M4深10	134	10	键3×10	184	16	204	85	117	147	276	104	5	50	8	EXT14z×2m×30R×5f	W30×2×30×14×9g						
55	292	M4深10	134	10	键3×10	184	16	215	62	98	128	288	83	5	50	8	EXT14z×2m×30R×5f	W30×2×30×14×9g						
58	330	M5深12	155.5	16	键5×16	228	24	251	91	116	142	328	104	7	56	10	EXT16z×2m×30R×5f	W35×2×30×16×9g						
80	343	M5深12	155.5	16	键5×16	228	24	265	65	91	120	339	80	7	56	10	EXT16z×2m×30R×5f	W35×2×30×16×9g						
78	338	M5深12	169	16	键5×16	236	24	261	99	124	150	336	112	8.5	63	12	EXT18z×2m×30R×5f	W40×2×30×18×9g						
107	351	M5深12	169	16	键5×16	236	24	276	71	98	126	348	86	8.5	63	12	EXT18z×2m×30R×5f	W40×2×30×18×9g						
117	384	M5深12.5	192	16	键5×16	266	24	294	111	137	164	382	125	10	70	14	EXT21z×2m×30R×5f	W45×2×30×21×9g						
160	399	M5深12.5	192	16	键5×16	266	24	310	79	108	137	396	96	10	70	14	EXT21z×2m×30R×5f	W45×2×30×21×9g						

油口尺寸表Ports Size

规格 Size	B (法兰连接)	B (螺纹连接)	S	R	G	T1	X1, X2	X3, A1
20	SAE3/4" (高压系列)	M27×2	SAE1 1/2" (标准系列)	M16×1.5	M14×1.5	M12×1.5	M14×1.5	M12×1.5
28	SAE3/4" (高压系列)	M27×2	SAE1 1/2" (标准系列)	M16×1.5	M14×1.5	M12×1.5	M14×1.5	M12×1.5
40	SAE3/4" (高压系列)	M33×2	SAE2" (标准系列)	M18×1.5	M14×1.5	M18×1.5	M14×1.5	M18×1.5
55	SAE3/4" (高压系列)	M33×2	SAE2" (标准系列)	M18×1.5	M14×1.5	M18×1.5	M14×1.5	M18×1.5
58	SAE1" (高压系列)	M42×2	SAE2 1/2" (标准系列)	M18×1.5	M14×1.5	M18×1.5	M14×1.5	M18×1.5
80	SAE1" (高压系列)	M42×2	SAE2 1/2" (标准系列)	M18×1.5	M14×1.5	M18×1.5	M14×1.5	M18×1.5
78	SAE1" (高压系列)	M42×2	SAE2 1/2" (标准系列)	M18×1.5	M14×1.5	M18×1.5	M14×1.5	M18×1.5
107	SAE1" (高压系列)	M42×2	SAE2 1/2" (标准系列)	M18×1.5	M14×1.5	M18×1.5	M14×1.5	M18×1.5
117	SAE1 1/4" (高压系列)	M48×2	SAE3" (标准系列)	M22×1.5	M14×1.5	M18×1.5	M14×1.5	M20×1.5
160	SAE1 1/4" (高压系列)	M48×2	SAE3" (标准系列)	M22×1.5	M14×1.5	M18×1.5	M14×1.5	M20×1.5

DR恒压变量 Constant Pressure Control

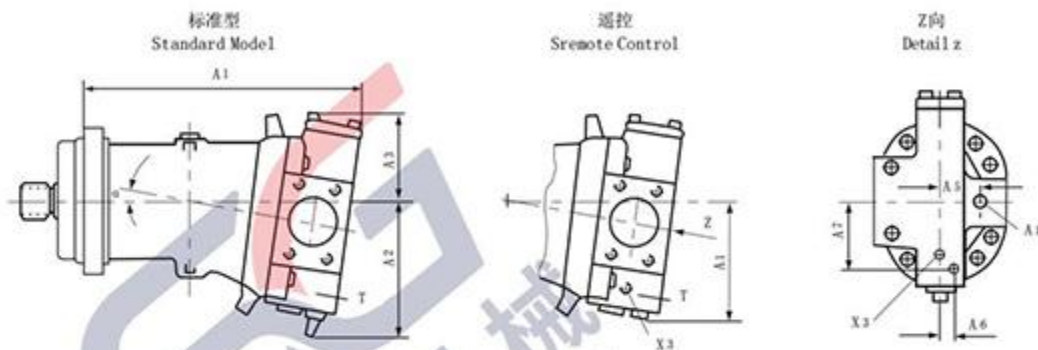

规格 Size	a	A ₁	A ₂	A ₃	A ₄	A ₅	A ₆	A ₇
20	9°	251	134	95	106	38	-	-
40	9°	315	166	107	127	40	14	53
58	9°	372	160	107	138	62	15	69
78	9°	380	180	114	147	60	14	70
117	9°	441	199	132	165	65	14	83

A1和X3仅用于遥控, 其余尺寸见LV。
A1 and X3 only for remote control. Other dimensions see LV.
T1: M12×1.5

MA手动变量 Manual Control

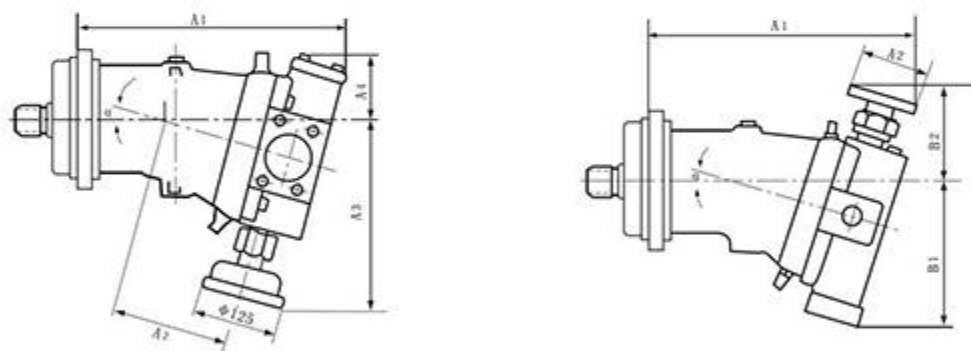

手轮朝下 handwheel downwards

规格 Size	a	A ₁	A ₂	A ₃	A ₄
20	9°	251	108	175	95
28	16°	260	108	190	80
40	9°	315	134	197	108
55	16°	323	134	215	89
58	9°	327	155.5	215	107
80	16°	380	155.5	235	86
78	9°	380	169	246	144
107	16°	390	169	270	92
117	9°	441	192	261	132
160	16°	450	192	285	107

手轮朝上 handwheel upwards

规格 Size	a	A ₁	A ₂	B ₁	B ₂
20	9°	-	-	-	-
28	16°	-	-	-	-
40	9°	317	100	175	132.5
58	9°	-	-	-	-
80	16°	-	-	-	-
78	9°	315	100	180	157.5
107	16°	383	100	270.5	132.5
117	19°	-	-	-	-
160	16°	445	100	225	143
250	26.5°	584	120	320	230

注: 手轮朝上或朝下, 订货时请说明。

Please give clear indication of the handwheels are upwards or downwards, when you order goods!