

A4VSO变量柱塞泵

配件示意图



A4VSO系列塞泵配件

- | | |
|----------------------|---------------------|
| 1、缸体 cylinder block | 7、配油盘 valve plate |
| 2、压板座 limiter | 8、轴瓦 saddle bearing |
| 3、压板 retainer | 9、止推板 thrust plate |
| 4、回程盘 retainer plate | 10、传动轴 drive shaft |
| 5、碟簧 disc spring | 11、球铰 ball guide |
| 6、柱塞 piston shoe | |

A4VSO变量柱塞泵

结构示意图

OH-A4VSO 变量柱塞泵 Variable Displacement Piston Pump OH-A4VSO

概述 Overview

本产品是一种斜盘式轴向柱塞变量泵，专为开式回路液压驱动设计的，采用通轴结构，额定压力可达35MPa。

This product is an axial piston pump in swash plate design for hydrostatic drives in open circuit operation. With through-shaft construction, its rated pressure is up to 35MPa.

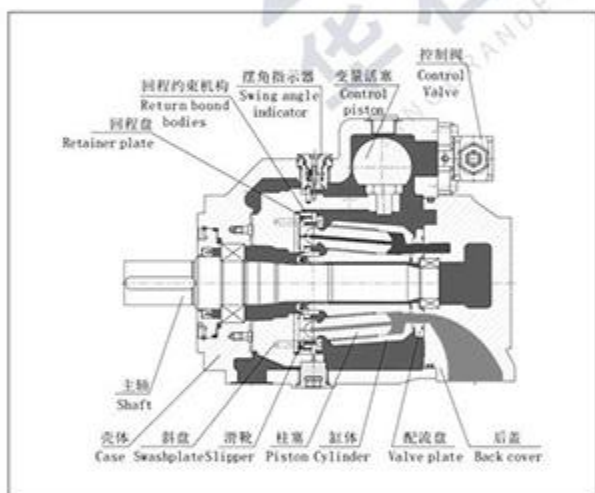

目录 CONTENTS

产品概述 Product overview	1
型号标识 Type code	2
技术参数 Technical data	4
功率与流量 Power and flow	6
外形尺寸 Dimensions	7
控制装置 Control devices	13
通轴驱动 Through drive	17
安装 Mounting	19

特点

- ※泵的流量正比于泵的转速和排量，调节它的斜盘摆角可进行排量的无级调节；
- ※通轴结构，可形成组合泵；
- ※位置约束回程机构；
- ※球面配流，柱塞围绕主轴倾斜布置；
- ※配置有斜盘摆角指示器；
- ※无级变量；
- ※优良的吸入性能；
- ※额定工作压力可达35MPa；
- ※控制响应时间短；
- ※低噪声；
- ※长寿命；
- ※优良的功率/重量比；
- ※模块化设计；
- ※驱动轴能承受轴向及径向负载；
- ※安装位置可选；
- ※可用HF液体工作，但运行参数有所降低。

Features

- ※The capacity of the pump is in proportion to its rotating speed and displacement; the stepless adjustment of the displacement can be materialized by regulating the swivel angle of its swash plate.
- ※With through-shaft structure, able to form combination pump;
- ※Position constraint return mechanism;
- ※Spherical flow distribution, the piston is inclined around the shaft;
- ※Equipped with swivel angle indicator of swash plate;
- ※Stepless variable displacement;
- ※Excellent suction performance;
- ※Rated working pressure of 35MPa;
- ※Fast control response;
- ※Low noise;
- ※Long lifespan;
- ※Excellent power/weight ratio;
- ※Modular design;
- ※The drive shaft is able to bear the axial and radial load;
- ※Optional installation position;
- ※It can operate with HF fluid to lower the operating parameter.

型号标识 Type Code

OH-	E	A4VS	0	250	DR	/	30	R	—	P	P	B	25	U	34
	1	2	3	4	5		6	7		8	9	10	11	12	13

1-工作介质 Operating Medium

矿物油 Mineral oil (无标识 No Code)	
阻燃液压油 HFA/HFB/HFC Hydraulic fluid	E

2-结构型式 Machinery Type

轴向柱塞, 斜盘式, 可变量 Axial piston, swash plate design, variable	A4VS
---	------

3-工作模式 Operational Mode

开式回路 Open circuit	0
-------------------	---

4-规格 Size

排量 $V_{gmax}(ml/r)$	40	71	125	180	250	355
---------------------	----	----	-----	-----	-----	-----

5-控制方式 Control Devices [★ 有货; ☆ 准备中; — 无货;]

压力控制	DR	●	●	●	●	●	●	●	DR..
并行操作压力控制	DP	●	●	●	●	●	●	●	DP..
流量控制	FR	●	●	●	●	●	●	—	FR..
压力和流量控制	DFR	●	●	●	●	●	●	—	DFR..
双曲线功率控制	LR	●	●	●	●	●	●	●	LR..)
手动控制	MA	●	●	●	●	●	●	●	MA..
电动机控制	EM	●	●	●	●	●	●	●	EM..
液压控制, 控制体积相关	HM	●	●	●	●	●	●	●	HM..
通过伺服/比例阀进行的液压控制	HS	●	●	●	●	●	●	●	HS..)
电动控制	EO	●	●	●	●	●	●	●	EO..)
液压控制, 先导压力相关	HD	●	●	●	●	●	●	●	HD..)
辅助速度控制	DS1	●	●	●	●	●	●	●	DS1..)
电动-液压控制系统 DFE1 系统解决方案SYHDFEE		●	●	●	●	●	●	—	DFE1..)

6-系列 Series

★	★	—	—	—	—	—	—	—	10
—	—	★	★	★	★	—	—	—	22
—	—	★	★	★	★	★	★	★	30

7-旋转方向 (从轴端看) Rotating Direction (View on Shaft End)

顺时针 Clockwise	R
逆时针 Counterclockwise	L

8-密封 Seals

丁腈橡胶NBR, 轴封氟橡胶Shaft seal FKM	P
氟橡胶FKM	V

9-轴伸 Shaft End

平键轴伸 Keyed shaft DIN6885	P
花键轴伸 Splined shaft DIN5480	Z

图表说明Chart shows: ●=可以供货Available, ○=在准备中In preparation, —=无Not available

10-安装法兰 Mounting Flange

	40	71	125	180	250	355	500	
ISO 4孔	★	★	★	★	★	★	—	B
ISO 8孔	—	—	—	—	—	—	★	H

11-油口型式 Ports Type

吸油口 Suction port S, 压力油口 Pressure port B, 辅助油口 Auxiliary port B ₁	13
吸油口 Suction port S, 压力油口 Pressure port B, 第二压力油口 The second pressure port B ₂	25

12.13-通轴驱动 Through Drive

通轴/规格 Size	40	71	125	180	250	300	355	370	500	代码		
无通轴驱动 Without Through Drive	■	■	■	■	■	■	■	■	■	N00		
有通轴驱动, 可带轴向柱塞泵, 齿轮泵或径向柱塞泵 With Through Drive, Mounting Dimensions are as follows	■	■	-	-	-	-	-	■	■	K		
通用通轴驱动, 可调整 Universal Through Drive, Mounting Dimensions are as follows	-	-	■	■	■	■	■	-	-	U		
安装法兰 Flange	花键轴/轴套 Splined Shaft	可接受的从泵 To Mount Pump	40	71	125	180	250	300	355	370	500	代码
ISO 125 4孔	32X2X14X9g	A4VSO 40	■	■	■	■	■	■	■	■	■	31
ISO 140 4孔	40X2X18X9g	A4VSO 71	-	■	■	■	■	■	■	■	■	33
ISO 160 4孔	50X2X24X9g	A4VSO 125	-	-	■	■	■	■	■	■	■	34
ISO 160 4孔	50X2X24X9g	A4VSO 180	-	-	-	■	■	■	■	■	■	34
ISO 224 4孔	60X2X28X9g	A4VSO 250	-	-	-	-	■	■	■	■	■	35
ISO 224 4孔	70X3X22X9g	A4VSO 355	-	-	-	-	-	■	■	■	■	77
ISO 315 8孔	80X3X25X9g	A4VSO 500	-	-	-	-	-	-	-	■	■	43
ISO 80 2孔	3/4" 19-4 (SAE A-B)	A10VSO 10, 18	□	■	□	□	□	□	□	□	□	B2
ISO 100 2孔	7/8" 22-4 (SAE B)	A10VSO 28	■	■	■	■	□	□	□	□	□	B3
	1" 25-4 (SAE B-B)	A10VSO 45	■	■	■	■	■	■	■	■	■	B4
ISO 125 2孔	1-1/4" 32-4 (SAE C)	A10VSO 71	-	■	■	■	■	■	■	■	□	B5
	1-1/2" 38-4 (SAE C-C)	A10VSO 100	-	-	□	□	□	□	□	□	□	B6
ISO 180 4孔	1-3/4" 44-4 (SAE D)	A10VSO 140	-	-	-	■	■	■	■	■	■	B7
82-2 (SAE A 2孔)	5/8" 16-4 (SAE A)	G2/GC2/GC3	■	■	■	■	■	■	■	■	■	01
	3/4" 19-4 (SAE A-B)	A10VO 10, 18	■	■	□	□	□	□	□	□	□	52
101-2 (SAE B)	7/8" 22-4 (SAE B)	A10VO 28, G3/G4	■	■	■	■	■	■	■	■	■	68
	1" 25-4 (SAE B-B)	A10VO 45, GC4/5	■	■	■	■	■	■	■	■	■	04
127-2 (SAE C)	1-1/4" 32-4 (SAE C)	A10VO 71	-	■	■	■	■	■	■	■	■	07
	1-1/2" 38-4 (SAE C-C)	A10VO 100, GC6	-	-	■	■	■	■	■	■	■	24
152-4 (SAE D)	1-3/4" 44-4 (SAE D)	A10VO 140	-	-	-	■	■	■	■	■	■	17
φ63 公制 4孔	用于平键轴 φ25	R4	■	■	□	□	□	□	□	□	□	57
带通轴驱动, 无轴套, 无变径法兰, 带端盖 With Through Drive Shaft, Without Coupler Close With Blind Flange			■	■	■	■	■	■	■	■	■	99

两台泵首尾串联, 即以通轴形式装配成一体, 称为组合泵, 串联的第二台泵称为从泵。

如果订购组合泵: 组合泵的型号为第一台泵的型号+第二台泵的型号。

Two pumps can be connected in series by their head and end, namely integrated to be a combination pump by the means of through-shaft, and the second pump of the series combination is called the subordinate pump.

In case of placing an order, the combination pump model equals to the model of the first pump + the model of the second. 组合泵型号示例 Illustration of combination pump model: 0H-A4VSO125DR/30R-PPB13U34+0H-A4VSO125DR/30R-PPB13N00

技术参数 Technical Data

1、工作压力范围 Range of operating pressure——进口侧 Side of inlet

吸入口S的压力（绝对压力） Pressure at suction port S (absolute pressure)

最低压力 $p_{s,min}$ 0.8 bar

最高压力 $p_{s,max}$ 30 bar

为了避免轴向柱塞泵损坏，吸入口S必须确保一个最低压力。这个最低进口压力取决于轴向柱塞泵的转速与排量：

In order to avoid damage to the axial piston unit, a minimum pressure must be ensured at the suction port S.

The minimum inlet pressure is dependent on the speed and displacement of the axial piston unit.

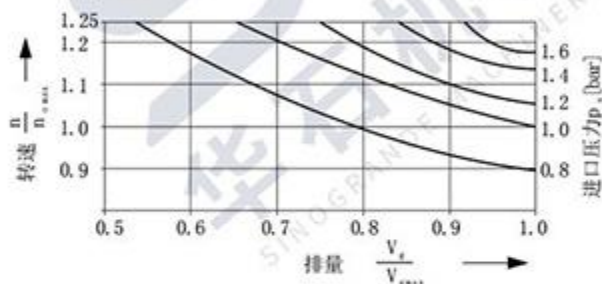

进口压力为静态的输入压力或增压压力的最小动态值。

Inlet pressure is static input pressure or minimum dynamic value of boost pressure.

2、工作压力范围 Range of operating pressure——出口侧 Side of outlet

B口的压力（绝对压力） Pressure at port B (absolute pressure)

额定压力 p_n 350 bar

峰值压力 p_{max} 400 bar

最低压力 p_{min} 15 bar

3、流动方向 Flowing Direction

S→B

4、壳体泄油压力 Case Drain Pressure

最大允许壳体泄油压力（绝对压力）取决于泵的转速，见图：

The allowed maximum case drain pressure (absolute pressure) depends on the rotating speed of the pump. Please see the figure.

最大壳体泄油压力（绝对压力）：

The maximum case drain pressure (absolute pressure)：

$p_{c,max}$ 4 bar

这是近似值，在某些工况下此值需减小。

This is approximate value. This value needs to be decreased under some operating conditions.

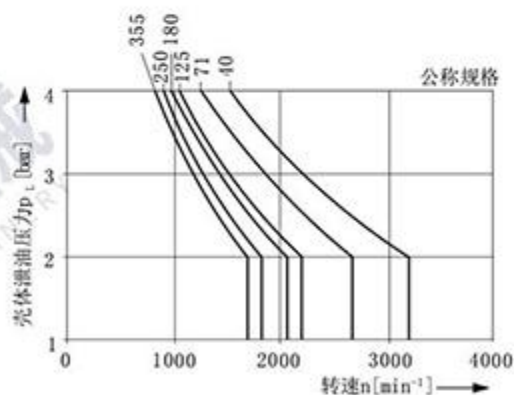

5、参数表（理论值） The Parameter List (theoretical values)

规格Size			40	71	125	180	250	355	500	
排量Displacement		V_{gmax}	ml/r	40	71	125	180	250	355	500
最大转速 ¹⁾ Max. Speed	$V_g = V_{gmax}$ 时	n_{imax}	r/min	2600	2200	1800	1800	1500	1500	1320
	$V_g < V_{gmax}$ 时		r/min	3200	2700	2200	2100	1800	1700	1600
流量Flow	$n = n_{imax}$ 时	q_{imax}	L/min	104	156	225	324	375	533	660
	$n = 1500$ r/min时		L/min	60	107	186	270	375	533	581
功率 Power $\Delta p = 350$ bar	$n = n_{imax}$ 时	P_{imax}	kW	61	91	131	189	219	311	385
	$n = 1500$ r/min时		kW	35	62	109	158	219	311	339
扭矩 Torque $V_g = V_{gmax}$	$\Delta p = 350$ bar时	T_{imax}	Nm	223	395	696	1002	1391	1976	2783
	$\Delta p = 100$ bar时	T	Nm	64	113	199	286	398	564	795
驱动轴上的惯性矩 Inertia moment of the drive shaft		J	kgm^2	0.0049	0.0121	0.03	0.055	0.0959	0.19	0.3325
壳体容积Volume of case			L	2	2.5	5	4	10	8	14
重量Weight			kg	39	53	88	102	184	207	320
驱动轴上允许负载 Permissible load of the drive shaft	最大轴向力 Max. axial force		N	600	800	1000	1400	1800	2000	2500
	最大径向力 Max. radial force		N	1000	1200	1600	2000	2000	2200	2000

1) $V_g = V_{gmax}$ 时的数值适用于吸油口S的进口压力为绝对压力1bar时的情况，当进口压力 p_s 增加或排量减小，则转速可增加， $V_g < V_{gmax}$ 时的数值为转速极限。

1) Once $V_g = V_{gmax}$, the value is applicable for the condition in which inlet pressure at Suction Port S equals to 1 bar, the absolute pressure; when the inlet pressure p_s increases or the displacement decreases, the rotating speed will increase; once $V_g < V_{gmax}$, the value amounts to the limit of the rotating speed.

轴承的冲洗Bearing flushing

对于A4VSO型轴向柱塞变量泵，在下列工况必须冲洗轴承以确保其长期工作的正常功能。

——采用特定的工作油液（非矿物油），由于其有限的润滑性能和较狭窄的工作温度范围；

——当采用矿物油工作在极限温度和粘度区域且变量泵采用垂直安装时（驱动轴向上）。

推荐使用轴承冲洗，以便确保前轴承和轴封有足够的润滑。

For the axial piston variable pump A4VSO at the following operating conditions bearing flushing is required for a safe, continuous operation.

——Applications with special fluids (non mineral oils) due to limited lubricity and narrow operating temperature range.

——Operation at critical conditions of temperature and viscosity with mineral oil and vertical mounting (drive shaft facing upwards).

Flushing is recommended in order to ensure lubrication of the front bearing and shaft seal.

轴承的冲洗，通过靠近变量泵前法兰的油口“U”进行。冲洗油液流过主轴承，并和泵的壳体泄漏油一起从泄油口排出。

对于10系列变量泵，当使用外部轴承冲洗时，泄油口节流阀必须打到最大（拧到底）。

Flushing is carried out via port “U” located in the front bearing and leaves the pump together with the case drain flow.

Regarding series 30, when using external bearing flushing the throttle screw at port U must be turned in to the end stop.

各规格的泵所需的冲洗油液流量为 (L/min) :
Depending on pump size, the following flushing flows are recommended:

规格Size	40	71	125	180	250	355
流量Flow	3	4	5	7	10	15

为了达到此给定的流量，在U口和壳体泄油口之间应分别保持约2bar。

These recommended flushing flows will cause a pressure drop of approx. 2 bar (series 10) and 3 bar (series 30) between the entrance to port U and the pump case.

特性曲线 Characteristic curves
 输入功率与流量 Drive power and flow

规格40

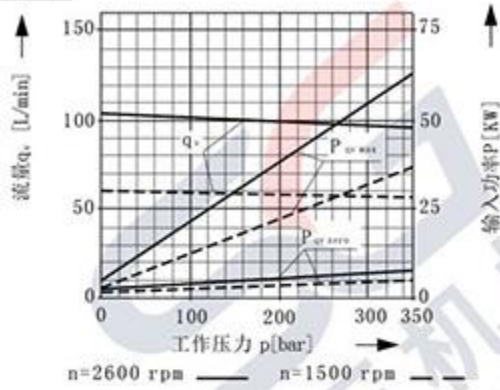

规格71

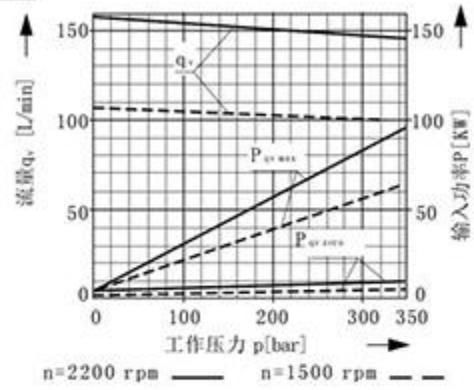

规格125

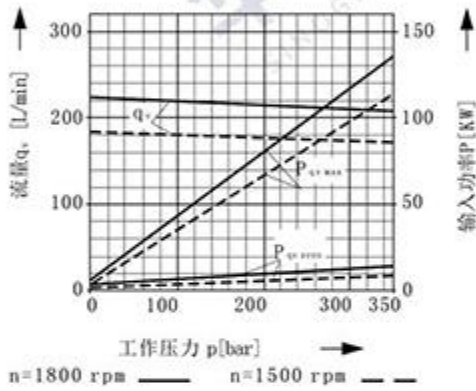

规格180

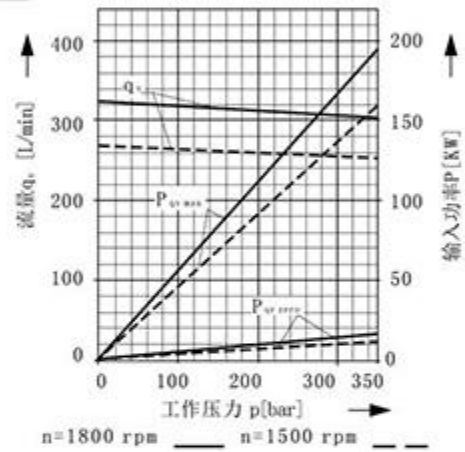

规格250

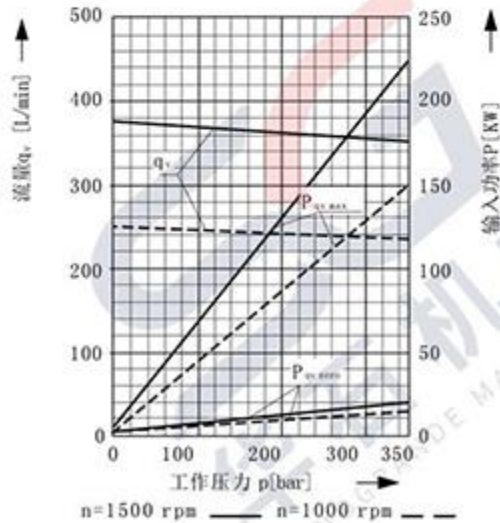

规格355

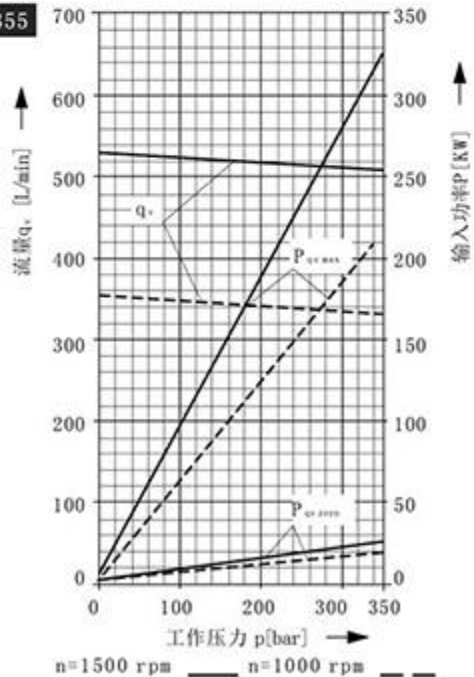

外形尺寸 规格40, 10系列 (图中示例的控制机构是压力控制)
Dimension Size 40, Series 10 (Example: pressure control)

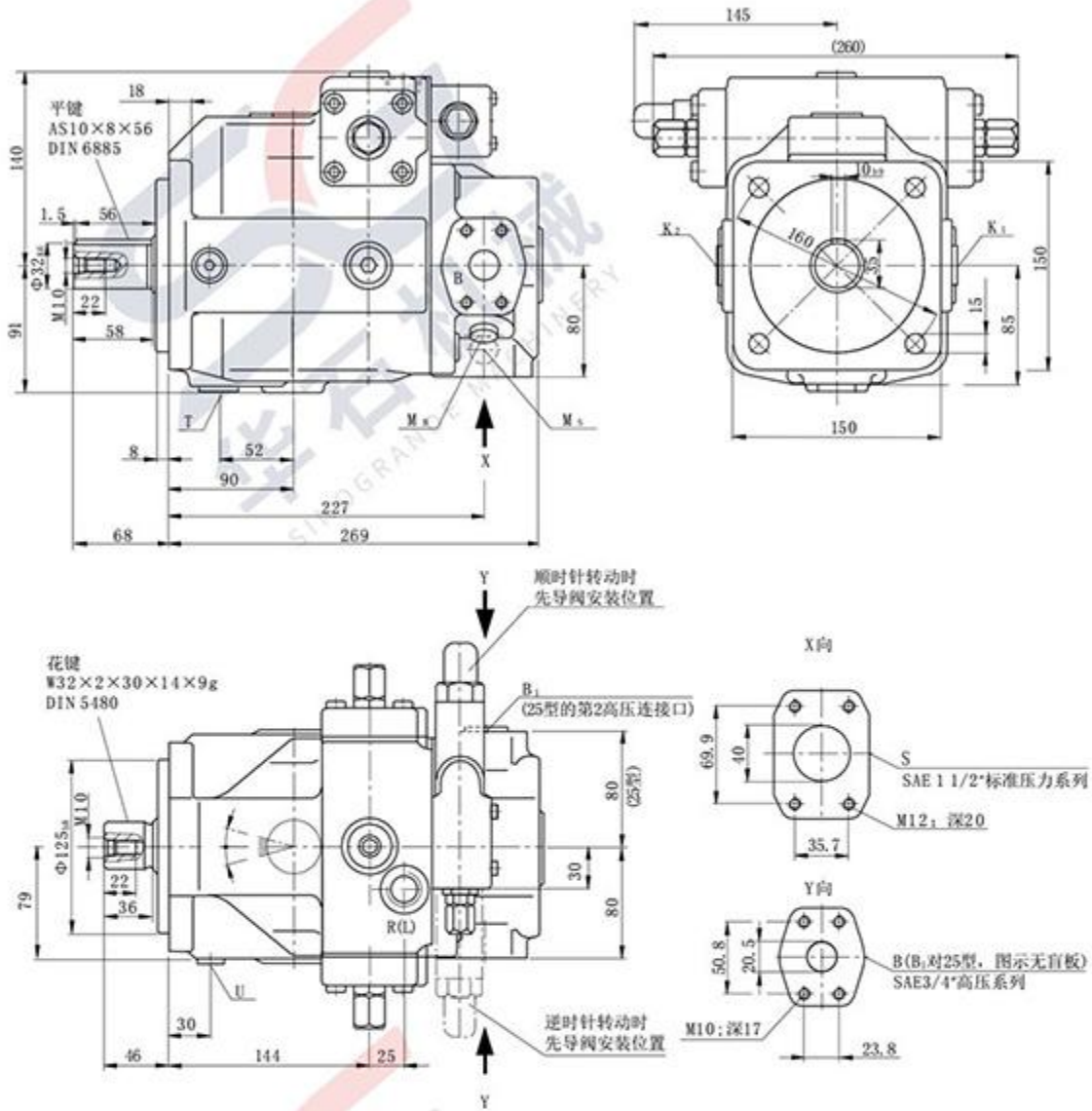

油口13型 Ports type 13

B 压力油口 pressure port

B₁ 辅助油口 auxiliary port

油口25型 Ports type 25

B 压力油口 pressure port

B₁ 第二压力油口 second pressure port

其他油口 Other ports

S 吸油口 suction port

K₁, K₂ 冲洗油口 flushing port

T 溢油口 drain port

M_s, M_t 测试点 measuring port

R(L) 注油口 filling port +排气口 bleed port

U 冲洗油口 flushing port

SAE3/4" (高压系列 high pressure series)

M22×1.5深14 (堵 plugged)

SAE3/4" (高压系列 high pressure series)

SAE3/4" (高压系列 high pressure series) (封闭 closed)

SAE1 1/2" (标准系列 standard series)

M22×1.5深14 (堵 plugged)

M22×1.5深14 (堵 plugged)

M14×1.5深12 (堵 plugged)

M22×1.5

M14×1.5深12 (堵 plugged)

外形尺寸 规格71, 10系列 (图中示例的控制机构是压力控制)
Dimension Size 71, Series 10 (Example: pressure control)

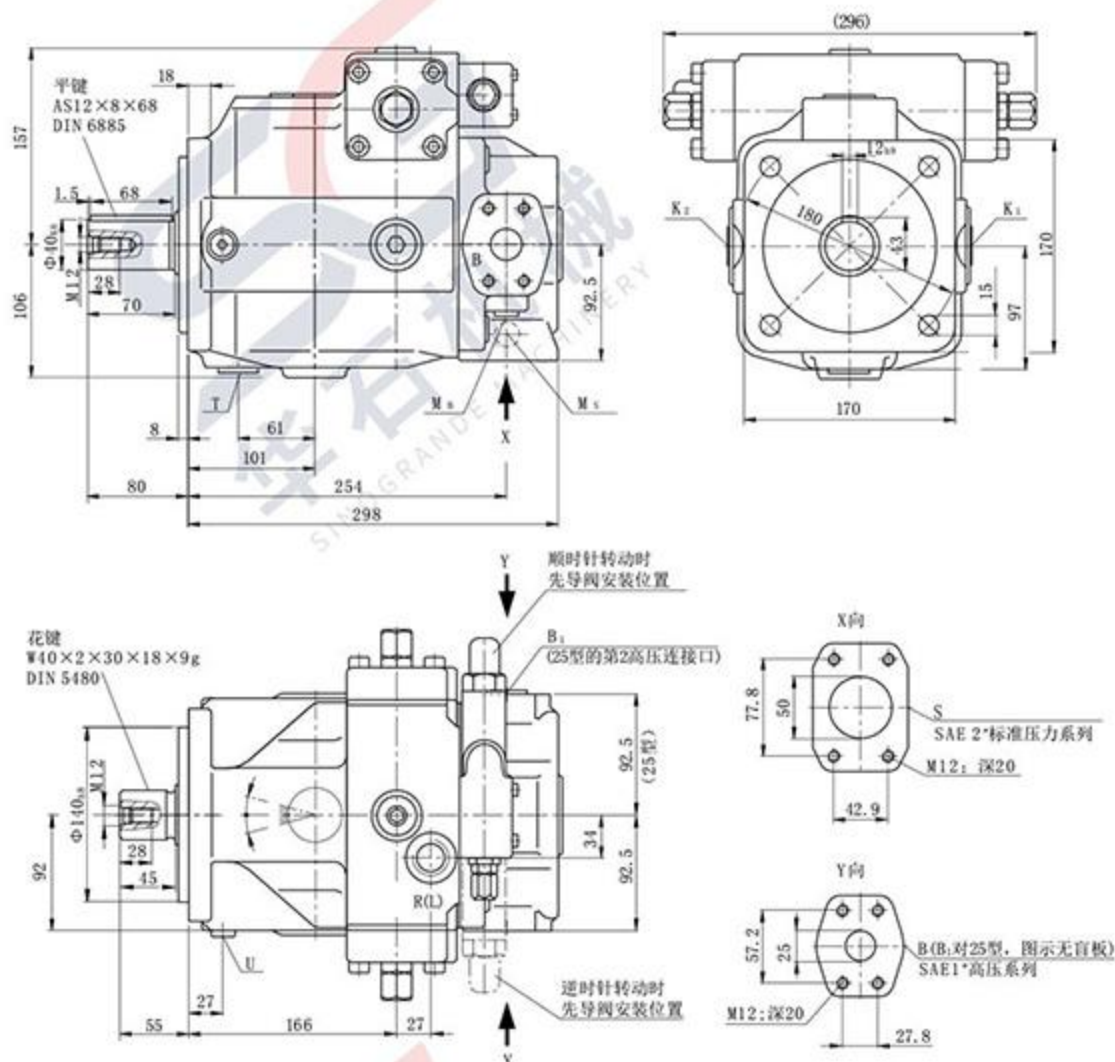

油口13型 Ports type 13

- B 压力油口 pressure port
- B₁ 辅助油口 auxiliary port

油口25型 Ports type 25

- B 压力油口 pressure port
- B₁ 第二压力油口 second pressure port

其他油口 Other ports

- S 吸油口 suction port
- K₁, K₂ 冲洗油口 flushing port
- T 泄油口 drain port
- M_s, M_s 测试点 measuring port
- R(L) 注油口 filling port+排气口 bleed port
- U 冲洗油口 flushing port

- SAE1" (高压系列 high pressure series)
- M27×2深 depth16 (堵 plugged)

- SAE1" (高压系列 high pressure series)
- SAE1" (高压系列 high pressure series) (封闭 closed)

- SAE2" (标准系列 standard series)
- M27×2深 depth16 (堵 plugged)
- M27×2深 depth16 (堵 plugged)
- M14×1.5深 depth12 (堵 plugged)
- M27×2
- M14×1.5深 depth12 (堵 plugged)

外形尺寸 规格125, 30系列 (图中示例的控制机构是压力控制)
Dimension Size 125 Series 30 (Example: pressure control)

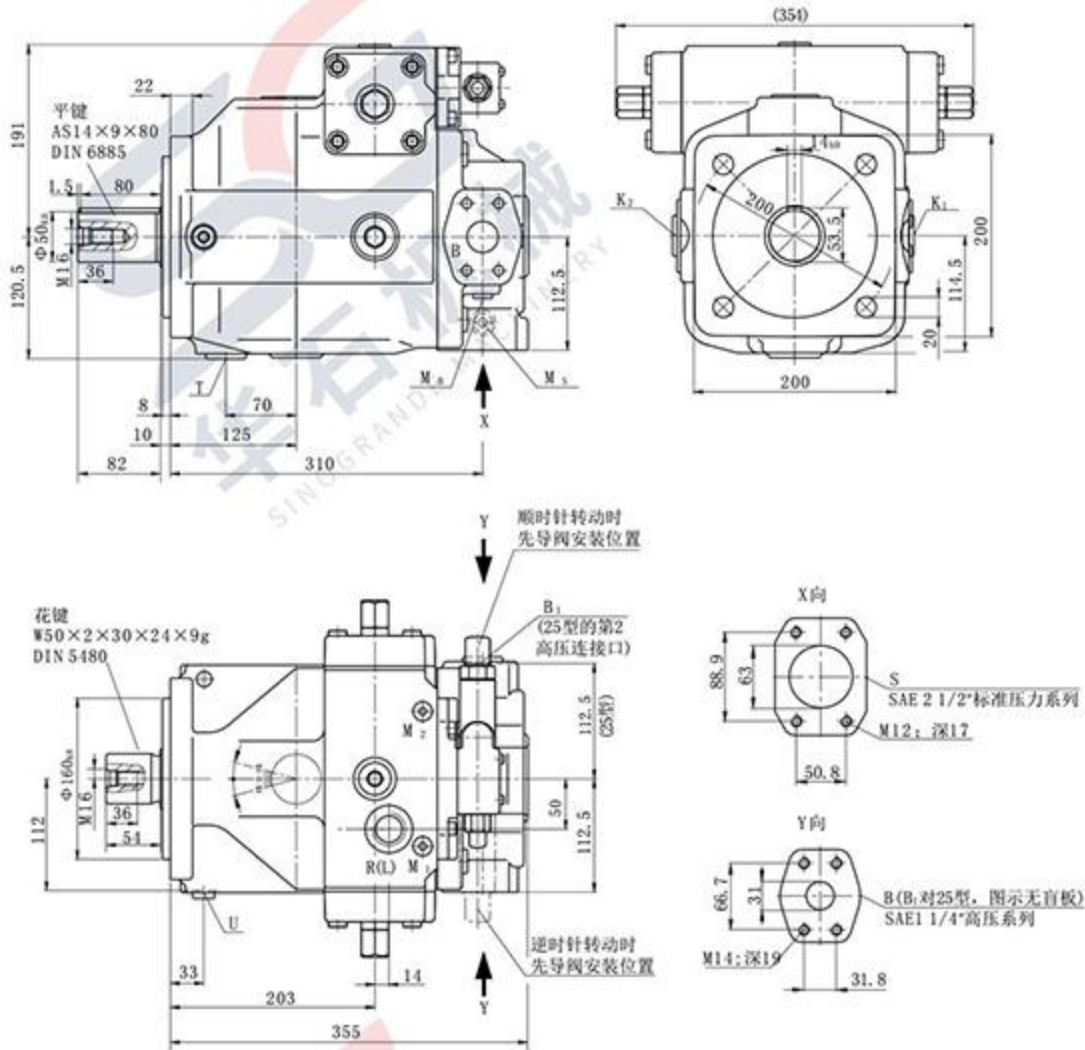

油口13型 Ports type 13

B 压力油口 pressure port

B₁ 辅助油口 auxiliary port

油口25型 Ports type 25

B 压力油口 pressure port

B₁ 第二压力油口 second pressure port

其他油口 Other ports

S 吸油口 suction port

K₁, K₂ 冲洗油口 flushing port

T 泄油口 drain port

M₁, M₂ 测试点 measuring port

R(L) 注油口 filling port + 排气口 bleed port

U 冲洗油口 flushing port

M₁, M₂ 变量机构的测试点 measuring port control device

SAE1 1/4" (高压系列 high pressure series)

M33×2深 depth18 (堵 plugged)

SAE1 1/4" (高压系列 high pressure series)

SAE1 1/4" (高压系列 high pressure series) (封闭 closed)

SAE2 1/2" (标准系列 standard series)

M33×2深 depth18 (堵 plugged)

M33×2深 depth18 (堵 plugged)

M14×1.5深 depth12 (堵 plugged)

M33×2

M14×1.5深 depth12 (堵 plugged)

M14×1.5 (堵 plugged)

外形尺寸 规格250, 30系列 (图中示例的控制机构是压力控制)
Dimension Size 250, Series 30 (Example: pressure control)

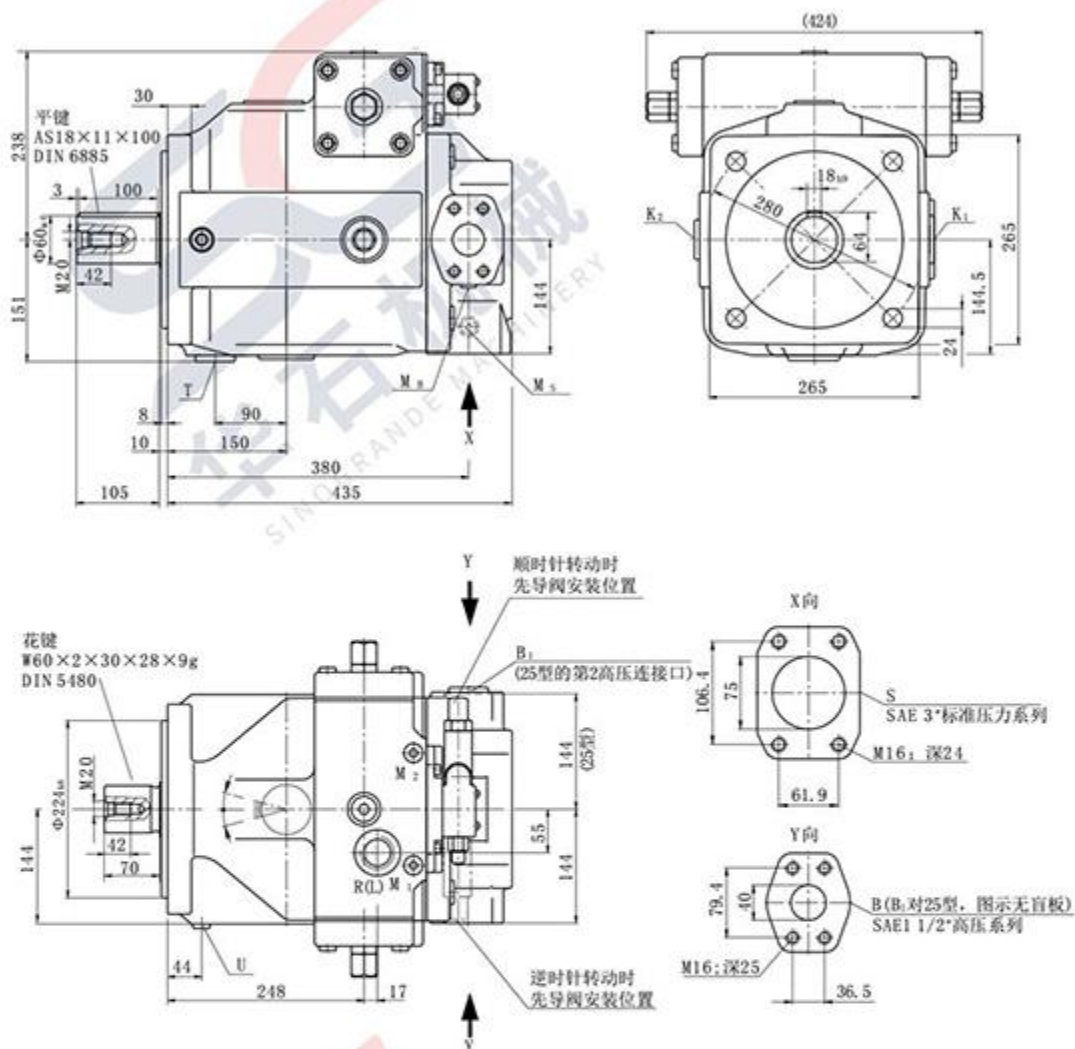

油口13型 Ports type 13

B 压力油口 pressure port

B₁ 辅助油口 auxiliary port

油口25型 Ports type 25

B 压力油口 pressure port

B₁ 第二压力油口 second pressure port

其他油口 Other ports

S 吸油口 suction port

K₁, K₂ 冲洗油口 flushing port

T 泄油口 drain port

M_a, M_s 测试点 measuring port

R(L) 注油口 filling port +排气口 bleed port

U 冲洗油口 flushing port

M_i, M_c 变量机构的测试点 measuring port control device

SAE 1 1/2" (高压系列 high pressure series)

M42×2 深 depth 20 (堵 plugged)

SAE 1 1/2" (高压系列 high pressure series)

SAE 1 1/2" (高压系列 high pressure series) (封闭 closed)

SAE 3" (标准系列 Standard series)

M42×2 深 depth 20 (堵 plugged)

M42×2 深 depth 20 (堵 plugged)

M14×1.5 深 depth 12 (堵 plugged)

M42×2

M14×1.5 深 depth 12 (堵 plugged)

M18×1.5 (堵 plugged)

外形尺寸 规格355, 30系列 (图中示例的控制机构是压力控制)
Dimension Size 355, Series 30 (Example: pressure control)

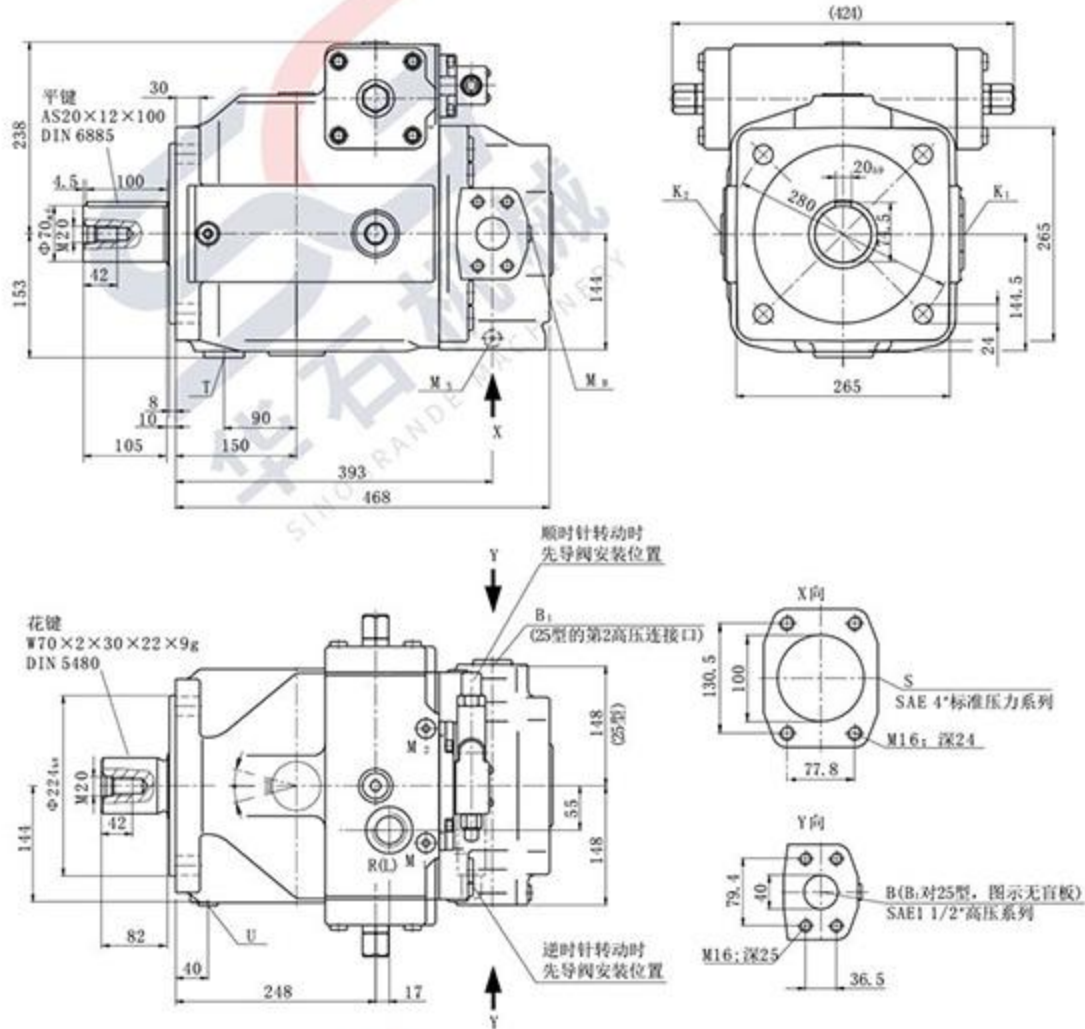

油口13型 Ports type 13

B 压力油口 pressure port

B₁ 辅助油口 auxiliary port

油口25型 Ports type 25

B 压力油口 pressure port

B₁ 第二压力油口 second pressure port

其他油口 Other ports

S 吸油口 suction port

K₁, K₂ 冲洗油口 flushing port

T 溢油口 drain port

M₁, M₂ 测试点 measuring port

R(L) 注油口 filling port +排气口 bleed port

U 冲洗油口 flushing port

M₁, M₂ 变量机构的测试点 measuring port control device

SAE1 1/2" (高压系列 high pressure series)

M42×2深 depth20 (堵 plugged)

SAE1 1/2" (高压系列 high pressure series)

SAE1 1/2" (高压系列 high pressure series) (封闭 closed)

SAE4" (标准系列 standard series)

M42×2深 depth20 (堵 plugged)

M42×2深 depth20 (堵 plugged)

M14×1.5深 depth12 (堵 plugged)

M42×2

M18×1.5深 depth12 (堵 plugged)

M18×1.5 (堵 plugged)

控制装置 Control Devices

1、压力控制DR Pressure Control DR

压力控制保持泵的输出压力在压力设定值，因此，泵只输出执行机构所需的流量。

设定范围20~350bar，可选：带远程压力控制DRG

Pressure control keeps the pressure constant within the control range of the pump at the pump outlet. There fore, the pump only delivers as much fluid as required by the actuators. Setting range 20~350bar.

Optional: with remote pressure control DRG

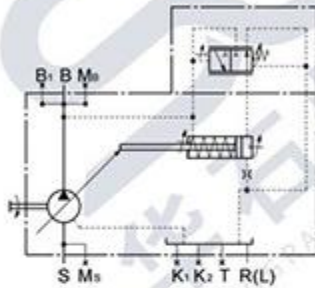
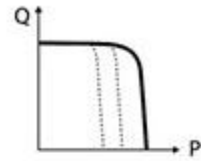

DR 原理图Schematic

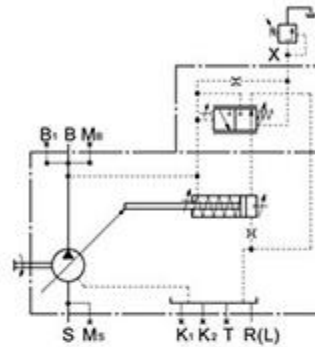

DRG 原理图Schematic

油口 Ports

X 先导压力油口，用于远程压力控制 Pilot pressure port, for remote pressure control M14×1.5 深12

2、流量控制FR Flow Control FR

泵的流量可以通过节流阀调节并且维持流量恒定。

可选：带远程压力控制FRG。

FR1及FRG1型式的X油口内的节流孔被封闭。

Pump flow may be regulated by means of a differential pressure at an orifice and maintains a constant regulating flow in a hydraulic system.

Optional: with remote pressure control FRG.

For model FR1 or FRG1 the orifice closed in the X port

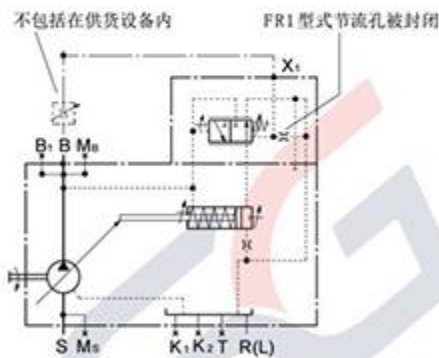
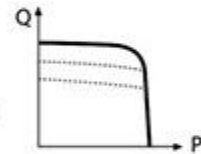

FR 原理图Schematic

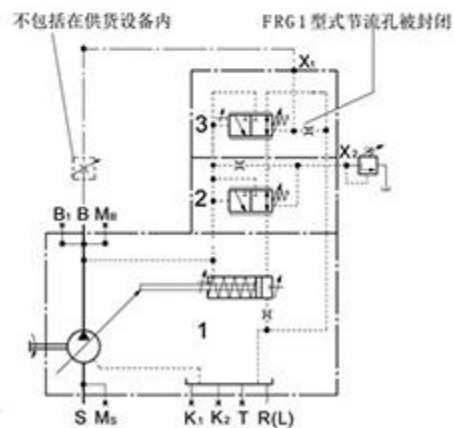

FRG 原理图Schematic

油口 Ports

X₁ 先导压力油口，用于流量控制 Pilot pressure port, for flow control M14×1.5 深12

X₂ 先导压力油口，用于远程压力控制 Pilot pressure port, for remote pressure control M14×1.5 深12

图中元件 Diagram components

1. OS-A4VS0轴向柱塞泵（带液压排量调节机构）Axial piston pump (with hydraulic positioning device)
2. 压力控制阀 Pressure control valve
3. 流量控制阀 Flow control valve

控制装置

3、压力与流量控制DFR Pressure and Flow Control DFR

在不断变化的工况下，保持泵输出的流量恒定，压力控制优先于流量控制

DFR1型式的X油口内的节流孔被封闭

This control maintains a constant flow from the pump even under varying operating conditions. Overriding this control is a mechanically adjustable pressure control.

Optional: For model DFR1 the orifice closed in the X port

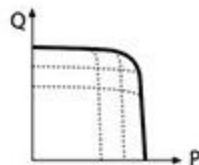

DFR 原理图Schematic

油口 Ports

X 先导压力油口，用于流量控制 Pilot pressure port, for flow control M14×1.5 深12

图中元件 Diagram components

1. 0H-A4VSO型轴向柱塞泵（带液压排量调节机构） Axial piston pump (with hydraulic positioning device)
2. 压力控制阀 Pressure control valve
3. 流量控制阀 Flow control valve

4、功率控制LR2 Pressure Control LR2

双曲线功率控制，能在泵的转速不变时，保持泵的驱动功率为不变の設定值。

可选：带压力控制LR2D，带远程压力控制LR2G

The hyperbolic power control maintains a constant preset drive power at the same input speed.

Optional: with pressure control LR2D, with remote pressure control LR2G

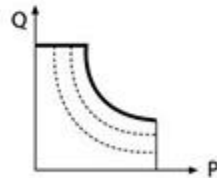

5、功率控制LR3 Pressure Control LR3

双曲线功率控制，能在泵的转速不变时，保持泵的驱动功率为不变の設定值。

其功率特性曲线可远程进行调节。

可选：带压力控制LR3D，带远程压力控制LR3G

The hyperbolic power control maintains a constant preset drive power at the same input speed. The power characteristics can be adjusted remotely.

Optional: with pressure control LR3D, with remote pressure control LR3G

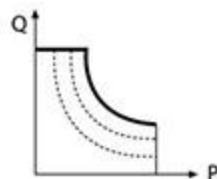

控制装置 Control Devices

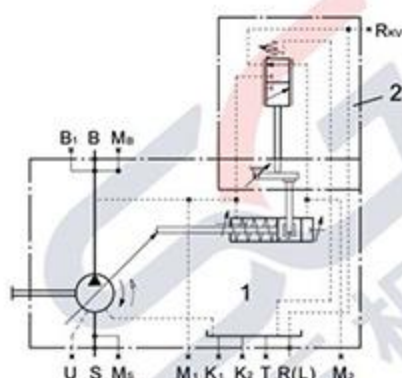

LR2 原理图Schematic

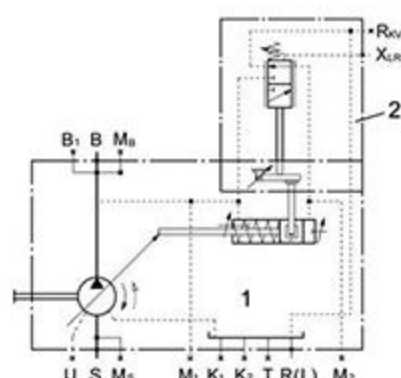

LR3 原理图Schematic

油口 Ports

R_{cv} 控制油外部回油口 External control oil return port M18×1.5, 深12

X_{sr} 先导压力油口, 用于远程功率控制 Pilot pressure port, for remote power control M14×1.5 深12

图中元件 Diagram components

1. OH-A4VS0型轴向柱塞泵 (带液压排量调节机构) Axial piston pump (with hydraulic positioning device)
2. 功率控制阀 Power control valve

…D 带压力控制 With Pressure Control

压力控制优先于功率控制, 即: 在设定压力值之下时按照功率控制工作。当达到压力控制阀上的设定压力时, 泵进入压力控制模式, 仅提供维持该压力所需的液压油液。

The pressure control overrides the power control, i.e. below the set pressure control level the unit follows the power control function. As soon as the pump output pressure reaches the pressure control level, the pump turns into the pressure control model and delivers only the amount of fluid as required to maintain this pressure.

…G 带远程压力控制 With Remote Pressure Control

压力限制阀连接至油口X_o, 用于远程控制。当达到设定压力(压力限制阀上的设定压力加压力控制阀上的压差)时, 泵进入压力控制模式, 仅提供维持该压力所需的液压油液。

Pressure relief valve is connected to port X_o, for remote control. As soon as the pump output pressure (relief valve setting plus pressure differential over the pressure control valve spool) reaches the pressure control level, the pump turns into the pressure control model and delivers only the amount of fluid as required to maintain this pressure.

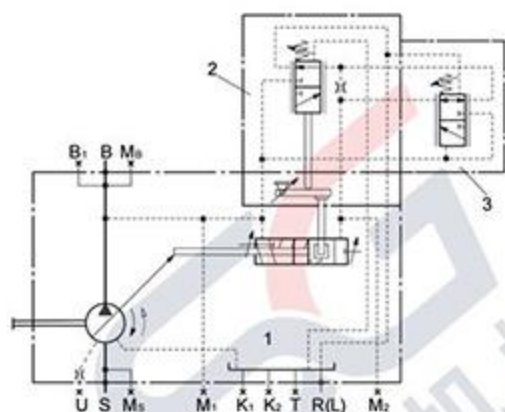

LR2D 原理图Schematic

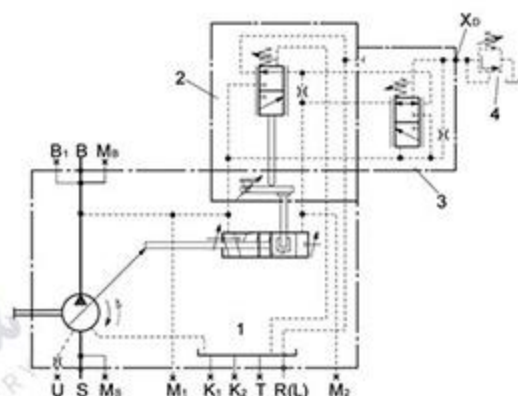

LR2G 原理图Schematic

油口 Ports

X_o 先导压力油口, 用于远程压力控制 Pilot pressure port, for remote pressure control M14×1.5, 深12

图中元件 Diagram components

1. OH-A4VS0型轴向柱塞泵 (带液压排量调节机构) Axial piston pump (with hydraulic positioning device)
2. 功率控制阀 Power control valve
3. 压力控制阀 Pressure control valve
4. 压力限制阀 (不包括在供货范围之内) Pressure relief valve (not in scope of supply)

控制装置 Control Devices

6、液压流量控制E02

借助于带斜盘摆角电反馈的比例阀，进行排量的无级调节。

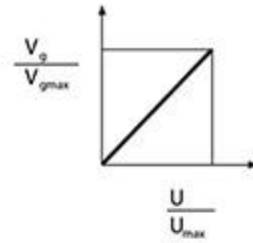
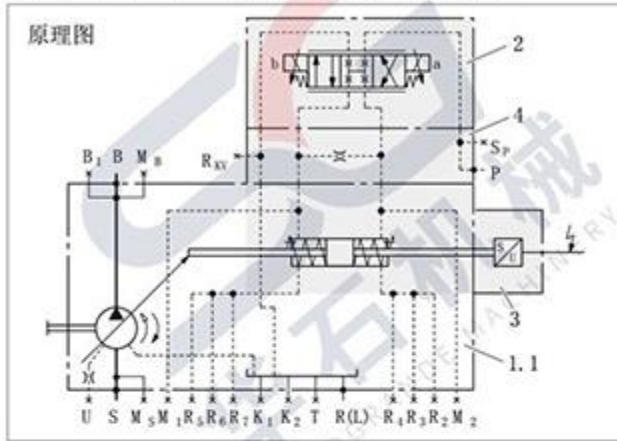

图中元件 Diagram components

- | | |
|-------------------------------|---|
| 1. A4VS0型轴向柱塞泵
(带机械排量调节机构) | 1. A4VS0 type axial piston pump
(with mechanical positioning device) |
| 2. 比例阀 | 2. Proportional valve |
| 3. 位置传感器 | 3. Position sensor |
| 4. 过渡板 | 4. Transition board |

7、电机控制EM Motor Control EM

用电机进行排量的无级调节。带可编程的顺序控制，借助于内置的限位开关和电位器进行排量的有级调节。

Stepless adjustment of displacement via an electric motor. Various intermediate displacement values can be selected with a programmed sequence control, by means of built on limit switches and an optional potentiometer for feedback signal.

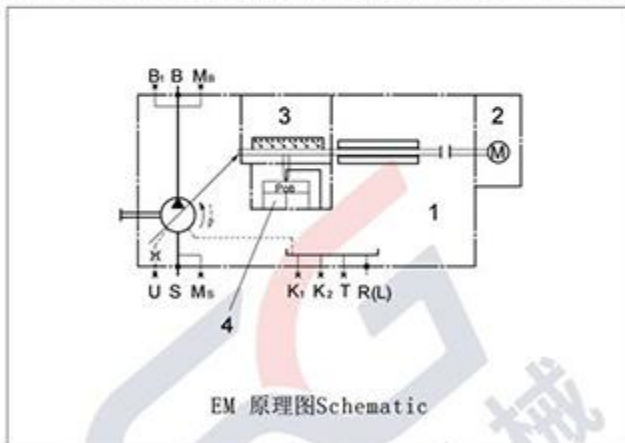
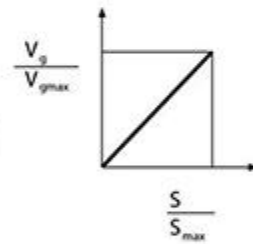

EM 原理图Schematic

图中元件 Diagram components

- | | |
|------------------------------|---|
| 1. 0H-A4VS0轴向柱塞泵 (带机械排量调节机构) | 1. Axial piston pump (with mechanical positioning device) |
| 2. 电机 | 2. Motor |
| 3. 限位开关 | 3. Limit switch |
| 4. 电位器 | 4. Potentiometer |

通轴驱动 Through Drive

OH-A4VSO型轴向柱塞泵可提供通轴驱动，可提供的通轴驱动型式见第2~3页“型号标识”。

我们推荐通轴驱动最多可串联三级（主泵与从泵共三台）。

OH-A4VSO axial piston pump can be equipped with a through drive, as shown in the type code on page 2-3.

We recommend that no more than three pumps be coupled together (main pump and following pump a total of three).

允许的输入转矩与通轴驱动转矩 Permissible input torque and through drive torque (单位Unit: Nm)

规格 Size	40	71	125	180	250	355	
花键轴伸 Splined Shaft							
主泵的最大输入转矩 Maximum input torque of the main pump	$T_{tot\ max}$	446	790	1392	2004	2782	3952
A型式 允许的通轴驱动转矩 Permissible through drive torque	$T_{D1\ max}$	223	395	696	1002	1391	1976
	$T_{D2\ max}$	223	395	696	1002	1391	1976
B型式 允许的通轴驱动转矩 Permissible through drive torque	$T_{D1\ max}$	223	395	696	1002	1391	1976
	$T_{D2\ max}$	223	395	696	1002	1391	1976
平键轴伸 Keyed shaft							
主泵的最大输入转矩 Maximum input torque of the main pump	$T_{tot\ max}$	380	700	1392	1400	2300	3557
A型式 允许的通轴驱动转矩 Permissible through drive torque	$T_{D1\ max}$	223	395	696	1002	1391	1976
	$T_{D2\ max}$	157	305	696	398	909	1581
B型式 允许的通轴驱动转矩 Permissible through drive torque	$T_{D1\ max}$	157	305	696	398	909	1581
	$T_{D2\ max}$	223	395	696	1002	1391	1976

转矩分配型式 Torque Distribution Pattern

分配型式A Distribution pattern A

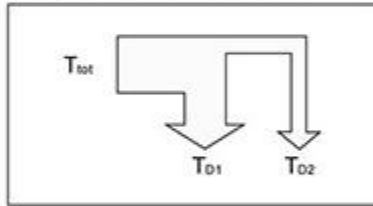

分配型式B Distribution pattern B

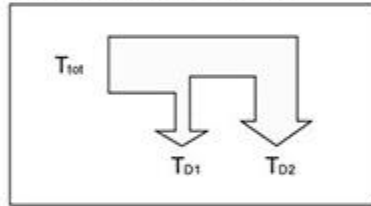

主泵安装法兰上的许用弯矩 Permissible mass moment of inertia referred to the mounting flange of the main pump

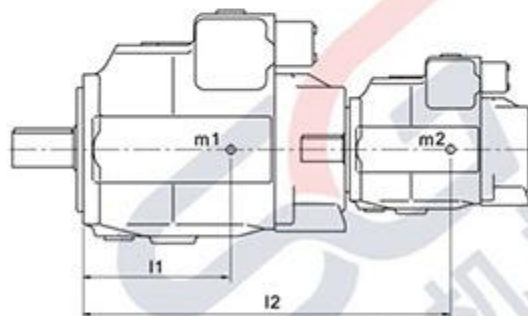

规格 Size	40	71	125	180	250	355
T_s	1800	2000	4200		9300	
$T_{s\ 10g}$	180	200	420		930	
m	39	53	88	102	184	207
l	120	140	170	180	210	220

T_s -许用弯矩 Nm

$T_{s\ 10g}$ -10g加速度时的许用弯矩 Nm

m_1 -主泵质量 Kg

m_2 -从泵质量 kg

l_1 -主泵重心与安装法兰的距离 mm

l_2 -从泵重心与主泵安装法兰的距离 mm

$$\text{弯矩 } T = m_1 \times l_1 \times \frac{1}{102} + m_2 \times l_2 \times \frac{1}{102} < T_s$$

T_s -Perm. mass moment of inertia (Nm)

$T_{s\ 10g}$ -Perm. mass moment at dynam acceleration of 10g (Nm)

m_1 -The quality of the main pump (kg)

m_2 -The quality of the following pump (kg)

l_1 -The distance between barycenter of main pump and mounting flange (mm)

l_2 -The distance between barycenter of following pump and mounting flange of main pump (mm)

通轴驱动 Through Drive

组合泵尺寸 Combination Pump Dimensions

从泵为OH-A4VSO型的尺寸 (mm)

Dimensions of following pumps OH-A4VSO

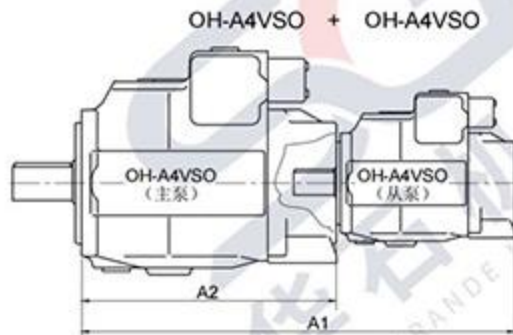

主泵 Main pump		40	71	125	180	250	355	
从泵 Following pump	A ₁	40	554	582	635	659	719	748
		71	—	611	664	688	748	777
		125	—	—	724	748	808	837
		180	—	—	—	788	828	857
		250	—	—	—	—	904	933
		355	—	—	—	—	—	962
A ₂	≤180	288	316	369	393	453	482	
	≥250	—	—	—	—	469	498	

从泵为OH-A10VSO型及OH-A10V0型的尺寸 (mm)

Dimensions of following pumps OH-A10V0 and OH-A10VSO

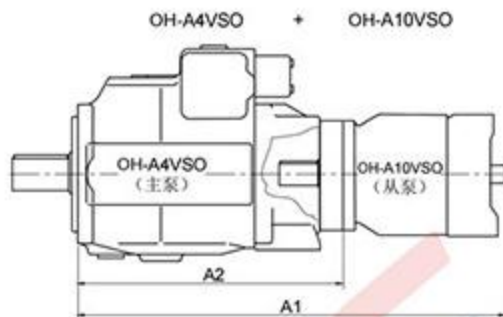

主泵 Main pump		40	71	125	180	250	355	
从泵 Following pump	A ₁	18	458	486	564	588	648	677
		28	496	497	575	599	659	688
		45	514	540	593	617	677	706
		71	—	580	628	652	712	741
		100	—	—	698	722	782	801
		140	—	—	—	744	791	820
A ₂		288	316	369	393	453	482	

主泵OH-A4VSO180与从泵OH-A10VSO140或OH-A10V0140串联, 尺寸A2为406。

The dimension A₂ is 406 for that OH-A4VSO180 pump couples OH-A10VSO140 or OH-A10V0 140 pump

安装 Mounting

◆一般要求 General requirements

安装位置任选。在试运行前，泵体必须灌满油液，并在工作时保持充满。

为了减少噪声，所有的连接管道（进油管、压力油管和壳体泄油管）需用柔性元件与油箱隔离，必须避免在壳体泄油管道上装单向阀，泄漏油应直接回到油箱，而通流截面不得减小。

The mounting position is discretionary. Before trial running, the pump body must be filled with fluid and kept filled while working.

To reduce noise, all connecting pipes (inlet pipe, pressure pipe and casting drain pipe) must be separated from the tank by using flexible components. Avoid mounting check valve on the casting drain pipe. The leaked oil shall return directly to the tank, but the through-flow section shall not be reduced.

◆垂直安装（轴端向上） Vertical mounting (with shaft end upward)

在垂直安装时，推荐轴承的冲洗如前所述，以确保前轴承的润滑。

In case of vertical mounting, we recommend flushing bearings as mentioned above to ensure the lubrication of the front bearings.

安装在油箱内 Mounting inside the tank

a) 当油箱的最低液面与泵的法兰面等高或更高时，《R/L》口、《T》口和《S》口可开放（见图1）。

When the minimum level in the tank is as same as or larger than the height of the flange face of the pump, port R/L, T and S can be open (see Figure 1)

b) 如油箱的最低液面低于泵的法兰面，《R/L》口、《T》口以及可能包括《S》口必须用管道连接，如图2所示。此情况与本节《安装在油箱外》中所述的相同。

When the minimum level in the tank is lower than the flange face of the pump, port R/L, T and possible port S must be connected with pipes, as shown in Figure 2. This situation is same as what is specified in Mounting outside of the Tank in this section.



图1

安装在油箱外 Mounting outside the tank

在安装前，泵水平卧置并灌满油液。《T》口通油箱，《R/L》口堵。在安装时的灌油：通过《R/L》口灌油，通过《T》通气，然后将《R/L》口堵死（见图2）。

Before mounting, the pump shall be placed horizontally and filled with fluid. Port T is connected with the tank and port R/L shall be blocked. Filling while mounting: Filling from port R/L and venting by port T and then blocking port R/L

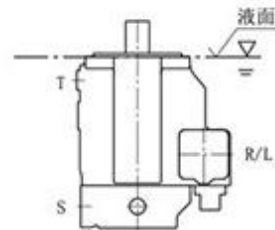
条件：泵的最低进口压力（吸入压力），必须不低于0.8 bar 绝对压力。如果要求低噪声运行则应避免将泵置于油箱之上。

Conditions: The minimum inlet pressure (absorption pressure) of the pump shall not be lower than 0.8 bar, the absolute pressure. If low noise running is required, the pump shall not be placed on the tank.



图2

◆ 卧置 Horizontally placed

将《T》，《K1》，《K2》或《R/L》口置于最高位置，用于灌油/通气并用于与泄油管连接。

Place port T, K1, K2 or R/L higher than the highest position for filling/venting and for connecting with drain pipe.

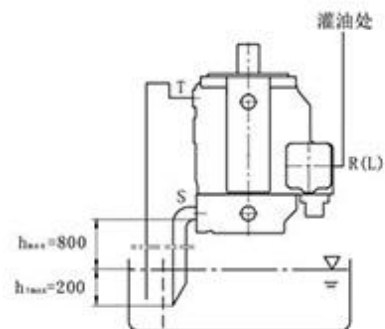
安装在油箱内 Mounting inside the tank

a) 当油箱的最低液面与泵的上端等高或更高，泄油口和《S》口可开放（见图3）。

When the minimum level in the tank is as same as or higher than the upper end of the drain port and port S can be open (see Figure 3)

b) 当油箱的最低液面比泵的上端低时，泄油口以及可能包括《S》口必须用管道连接（见图4）。此情况如同本节《安装在油箱外面》中a)项所述。

When the minimum level in the tank is lower than the upper end of the pump, the drain port and possible port S must be connected with pipes. (See Figure 4). This situation is same as what is specified in a) Mounting outside of the Tank in this section.

在试运行前应用油液灌满泵体。

Before trial running, the pump body must be filled with fluid.

安装在油箱外 Mounting outside the tank

在试运行前用油液灌满泵体。

Before trial running, the pump body must be filled with fluid.

a) 如安装在油箱之上，请见图4。

For mounting on the tank, see Figure 4.

条件：泵的最低进口压力（吸入压力），必须不低于0.8 bar 绝对压力。如果要求低噪声运行则应避免将泵置于油箱之上。

Conditions: The minimum inlet pressure (absorption pressure) of the pump shall not be lower than 0.8 bar, the absolute pressure. If low noise running is required, the pump shall not be placed on the tank.

b) 如安装在油箱之下，《R/L》和《S》口用管道连接，如图5所示。

For mounting under the tank, port R/L and S must be connected with pipes, as shown in Figure 5.



图3



图4

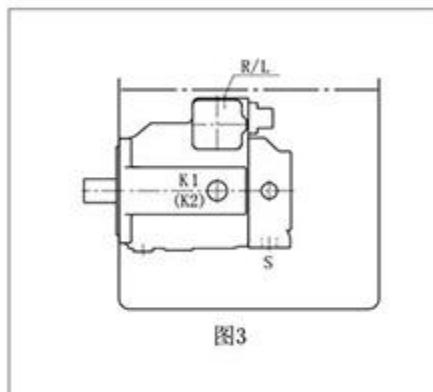
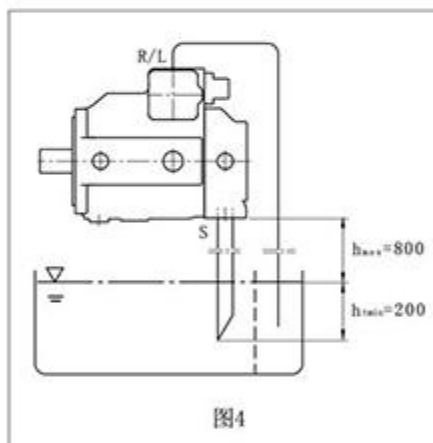
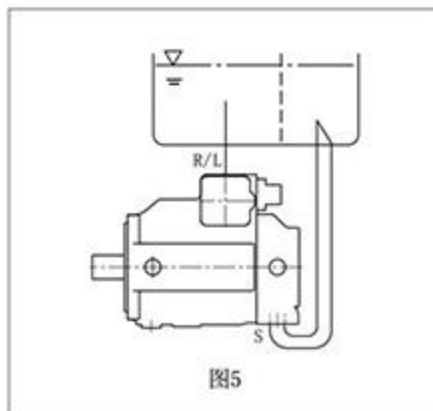

图5